

**TECHNICAL MANUAL**

**TRANSPORTABILITY GUIDANCE  
GENERAL RULES AND SUGGESTED PROCEDURES FOR  
LOADING AND SECURING MILITARY CARGO IN  
CLOSED RAILCARS**

THIS PUBLICATION IS A COURTESY QUICK COPY FROM THE UNITED STATES ARMY PUBLICATIONS DISTRIBUTION CENTER, ST. LOUIS, MISSOURI, TO MEET YOUR NEEDS WHILE WE REPLENISH OUR REGULAR STOCK.

**TRANSPORTABILITY GUIDANCE**

**GENERAL RULES AND SUGGESTED PROCEDURES FOR LOADING AND SECURING  
 MILITARY CARGO IN CLOSED RAILCARS**

	Paragraph	Page
Introduction.....	1	3
General.....	2	3
General Rules .....	3	24
Loading of Carload Shipment of Barrels, Drums, or Kegs in Closed Railcars .....	4	26
Fiberboard Container Loaded By Bonded Block and Palletized Methods.....	5	33
Procedures for Handling and Bracing of Mixed Merchandise.....	6	35
Loading of Hazardous Materials.....	7	37
APPENDIX A. REFERENCES .....	--	47
B. AAR DESIGNATING LETTERS AND DEFINITIONS .....	--	49
C. DICTIONARY OF STANDARD TERMS .....	--	50
LIST OF ILLUSTRATIONS		

<u>Figure</u>	<u>Title</u>	<u>Page</u>
1	Selection of material.....	4
2	Holding power of nails .....	4
3	Nails in lateral resistance in backup cleats .....	5
4	Nails in lateral resistance in staggered pattern .....	5
5	Nails in lateral resistance for diagonal bracing to side walls .....	6
6	Floor blocking.....	6
7	Cross car bracing .....	8
8	Single "K" brace reinforcing cross braces .....	8
9	Floor diagonals .....	9
10	Top holddown bracing .....	9
11	Bracing top-heavy articles-machinery .....	10
12	Bracing top-heavy articles-containers .....	10
13	Fillers between layers. Rigidly braced load .....	11
14	Cross bracing .....	11
15	Pocket cleats .....	12
16	Incomplete layer bracing .....	13
17	Side or center bracing .....	13
18	Method of cross bracing heavy wooden boxes .....	14
19	Side or center bracing to fill car voids .....	14
20	Side bracing .....	15
21	End gate .....	15
22	Divisional gate held in place by vertical cleats .....	16
23	Divisional gate held in place by horizontal cleats .....	16
24	Divisional gate nailed to car wall .....	16
25	Side elevation of double faced gate .....	16
26	Center gate.....	17
27	Use of vertical brace when long span exists to prevent buckling of lengthwise spreaders .....	17
28	Bracing affixed to doorway protection .....	18
29	Bracing affixed to doorway protection and side walls .....	19
30	Doorway protection for rough freight only .....	19
31	Flush doorway protection for cars with wooden door posts .....	19
32	Flush doorway protection .....	20
33	Flush doorway protection in cars with steel door posts .....	20
34	Doorway protection.....	21
35	Steel strap reinforced fiberboard doorway protection .....	21
36	Steel strap reinforced paper or fiberboard retaining strip doorway protection .....	21
37	Steel straps .....	22
38	Application of flat steel straps to car wall .....	23

<u>Figure</u>	<u>Title</u>	<u>Page</u>
39	Application of round wire to car wall.....	23
40	Steel straps applied over and under load .....	23
41	Plan view showing application of steel straps over and over and under load.....	23
42	Weight concentration percentages .....	25
43	Application of bilge protection .....	27
44	Nesting of crosswise rows .....	27
45	Bracing of units. Heavily loaded containers .....	28
46	Fillers between layers-rigidly braced load .....	28
47	Tierces double-decked floating load .....	29
48	Tierces loaded in equipped cars .....	29
49	Anchored load with partial layer .....	30
50	Wood bracing of light-gauge, straight-side metal drums.....	30
51	Loading heavy-gauge, heavy-duty drums in one layer only.....	31
52	5-4-5 Nested loading pattern .....	32
53	4-3-4 Nested loading pattern .....	32
54	4-4 (equal number) Nested pattern .....	32
55	Bracing doorway area.....	33
56	Detail of "K" brace .....	33
57	Rigid braced method of loading metal drums with rolling hoops .....	34
58	Bracing of partial layer.....	35
59	Application of fiat steel strapping to car wall .....	35
60	Draping one end of car with steel straps for anchored load .....	36
61	Guide row .....	37
62	Fiberboard material or bulkheads used to fill vacant space .....	37
63	Divider sheets.....	37
64	Summarizing recommended car loading practices .....	38
65	Bonded block pattern A .....	39
66	Bonded block pattern B.....	39
67	Bonded block pattern C .....	40
68	Maximum floor covering conventional car .....	41
69	Specially equipped cars .....	42
70	Stowage of different size lading .....	43
71	Freight with narrow bases.....	44
72	Doorway protection using side blocking .....	45
73	Doorway protection for cars with steel door posts .....	46
74	Plan view of car .....	51
75	Side view of car .....	51
76	Center gate .....	51

## 1. Introduction

a. This manual provides basic rules and procedures for proper application of materials used in loading and securing military cargo in closed railcars.

b. Information contained in this manual is extracted from the Association of American Railroads (AAR) Circular 42-D, *General Rules Covering Loading of Carload Shipments of Commodities in Closed Cars*; AAR Pamphlet 14, *Rules Regulating the Safe Loading of Freight in Closed Cars and Protection of Equipment*; and other AAR pamphlets covering specific commodities (app A). These AAR rules provide general information with respect to materials and procedures to be used in loading, blocking, and bracing commodities to be shipped. The AAR rules apply only within CONUS while the suggested loading procedures are applicable worldwide. AAR loading pamphlets on specific commodities may be obtained from the Freight Loading and Container Section, Association of American Railroads, 59 East Van Buren Street, Chicago, Illinois 60605.

c. The reporting of errors, omissions, and recommendations for improving this manual by the user is encouraged. Reports should be submitted on DA Form 2028 (Recommended Changes to Publications and Blank Forms) and forwarded to the Director, Military Traffic Management and Terminal Service Transportation Engineering Agency, ATTN: MTT-GDP, P.O. Box 6276, Newport News, Virginia 23606.

## 2. General.

### a. General Information.

(1) Boxcars are primarily employed to transport valuable commodities and products requiring protection from the weather or against breakage. Besides the plain type of box car intended for ordinary freight traffic there are boxcars made to accommodate the products peculiar to certain industries such as automobile parts, lumber, grocery products, appliances, and some bulk materials. Nearly a third (512,000) of the 1,710,659 railcars in service in 1973 were classed as boxcars. Of these approximately 25 percent were so equipped that they were assigned to specific services.

(2) Boxcars of 40 and 50-foot lengths in either 40 or 50-ton capacities constituted practically all the models built in the 40 years ending about 1960. The AAR Mechanical Division, in cooperation with the American Railway Car Institute, even prepared highly standardized designs that were the basis for hundreds of thousands of single and double-sheathed cars built over the four decades. Starting in the

early 1960's, the increases in length, cubic capacity, and weight carrying ability, which were sought for all types of freight cars, produced a series of spectacular jumps in boxcar size and capacity. The 60 and 86-foot cars in 70 and 100-ton designs were introduced generally for automobile parts service. Other high-cube designs have also been developed for household appliances.

(3) Because of the fragile nature of many commodities transported in boxcars, a higher percentage of these cars are fitted with sliding sill and end-of-car cushioning than has been the case for any other type of car. Load-stowing and load-retaining devices are more generally applied in boxcars for the same reason.

(4) As the use of lift trucks and other materials handling equipment has grown, there has been increasing emphasis on door openings through which these machines can maneuver readily. Shippers have been seeking wider door openings. There are now several types of cars on which the entire side opens to facilitate materials handling operations. Another popular arrangement has been a combination of a single sliding door and a single plug door on each side of the car to give the opening normally produced by the double sliding door arrangement. The plug door single and double arrangements have been used exclusively on a growing number of cars.

(5) The insulated boxcar has been increasingly popular. This type of car now handles many of the shipments that formerly moved in heated refrigerator cars. Many shippers also specify them for shipments that could be damaged by condensation.

(6) Express boxcars equipped for passenger train operation are built essentially the same as those in freight service but are fitted with air, signal, and steam-heat pipes and have passenger-car brakes and high-speed trucks.

(7) Listed in appendix B are the AAR designating letters and definitions for boxcar types of railcars.

(8) The Association of American Railroads loading rules are formulated for the purpose of providing safe and economical methods of loading railcars. The materials and procedures specified in these rules are *minimum requirements* based on exacting studies and experiences over a period of many years. All of the general rules and requirements for blocking and securing loads outlined in AAR Pamphlet 14 and AAR Circular 42D are *mandatory*, unless otherwise provided.

(9) The general rules contained in AAR Circular 42-D govern the loading of various com

modities in closed railcars and are primarily to insure the safe movement of the car and the load from origin to destination. The AAR rules do not provide for the protection of commodities from the elements or from other forms of damage. Additional protection from damage is a matter to be decided between the shipper and receiver of the commodity.

(10) The loading, blocking, and bracing of explosives, flammables, and other dangerous commodities must be in accordance with the requirements of Bureau of Explosives Tariffs (app A).

(11) Cars should be clean; have sound floors, roofs, and side and end walls; and be free from protruding nails or other projections that might cause damage to the contents.

(12) Commodities must be loaded or blocked and braced tightly lengthwise and crosswise so as to eliminate slack space, which is the primary cause of damage. Slack space between commodities should be taken up by blocking, bracing, center gates, etc., which should be secured in accordance with methods outlined in this manual and AAR pamphlets listed in appendix A.

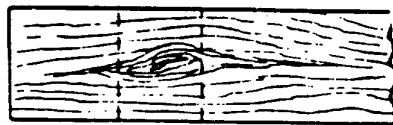
(13) Rough edges or projections of some commodities or containers must be covered with a suitable material to prevent damage.

(14) No commodities of a contaminating nature should be loaded in the same car with commodities liable to be contaminated, unless properly segregated and protected.

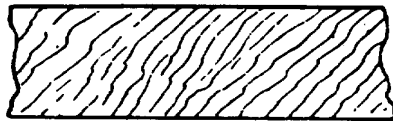
**Important Features to be Watched in Selecting Blocking and Bracing Material**



*Knots that interfere with nailing should be cut off at dotted line.*



*Large knots weaken members. Cut off as shown and use short pieces for cleats, etc.*



*Never use lumber with cross grain for structural members.*



*Small amount of bark does not mean that lumber should be rejected.*

Figure 1. Selection of material

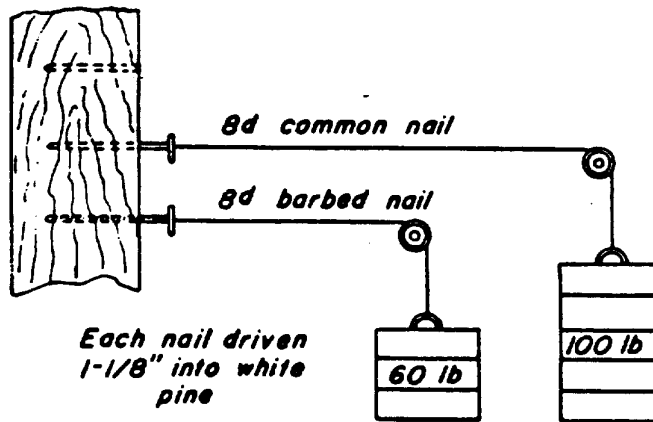


Figure 2. Holding power of nails.

(15) In *stop-off* cars each individual consignment should be separately braced and blocked, where possible, in order to reduce the requirement for restoring, blocking, and bracing.

*b. Lumber, Nails, and Nailing.*

(1) Properly seasoned lumber should be used for car bracing and blocking. Green lumber should not be used as it does not have the strength or stiffness qualities of dry lumber. Green lumber under certain conditions will give off quantities of moisture that can have harmful effects on some commodities loaded in the car.

(2) Lumber used for blocking and bracing should be properly stored and protected from the elements to prevent rot or decay.

(3) When selecting the size of lumber for bracing and blocking, consideration should be given to the weight, size, nature of the commodity to be secured within the car, and the capability of the blocking and bracing to withstand impacts of up to 8 miles per hour.

(4) All blocking and bracing material should be selected from sound lumber free from crossgrain, dry rot, knot holes, checks, or splits that will affect its strength or interfere with proper nailing (fig 1).

(5) The dimensions shown in this manual for lumber to be used in the construction of center gates, end gates, doorway bracing, and blocking are the nominal dimensions for commercial sizes of lumber. Table 1 indicates the nominal and actual thickness of commercial lumber generally used for this purpose. Lumber

that is less than actual thickness shown in table 1 should not be used. Table 2 shows the species of wood most commonly used for bracing. It is recommended that medium woods be used. The next larger commercial size should be used for bracing constructed with soft woods. Table 3 shows the standard sizes for soft and medium woods.

(6) Nails should not be used where they are in direct tension, but in lateral resistance as shown in figures 3, 4, and 5.

(7) Nails should be driven into the side grain of lumber as this provides 50 percent more holding power than when driven into the end grain. All nails should be driven straight.

(8) Nails should be of sufficient length so that two-thirds of the length of the nail goes into the member holding the point. Table 5 indicates sizes of nails, spikes, or bolts to be used for various thicknesses of material.

(9) Nails that will protrude beyond the thickness of car sides or through the car floor must not be used, as they cause damage to car equipment.

*c. Blocking and Bracing.*

(1) All floor blocking must be securely nailed to car floors and reinforced with backup cleats (fig 3 and 6) extending over three or more floor boards. Backup cleats should be of material not less than 2 inches by 4 inches and at least 18 inches in length.

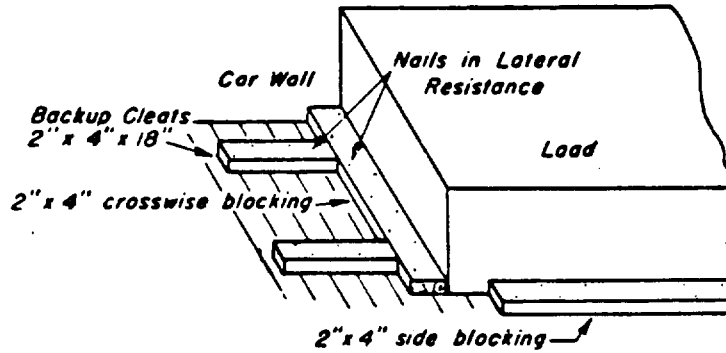


Figure 3. Nails in lateral resistance in backup cleats.

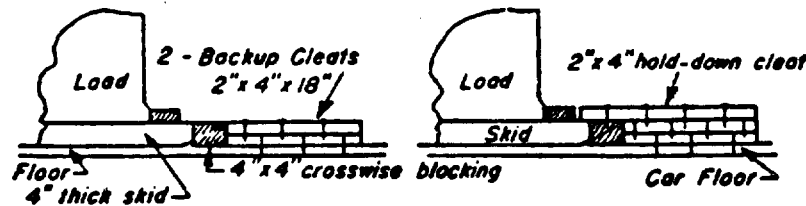


Figure 4. Nails in lateral resistance in staggered pattern.

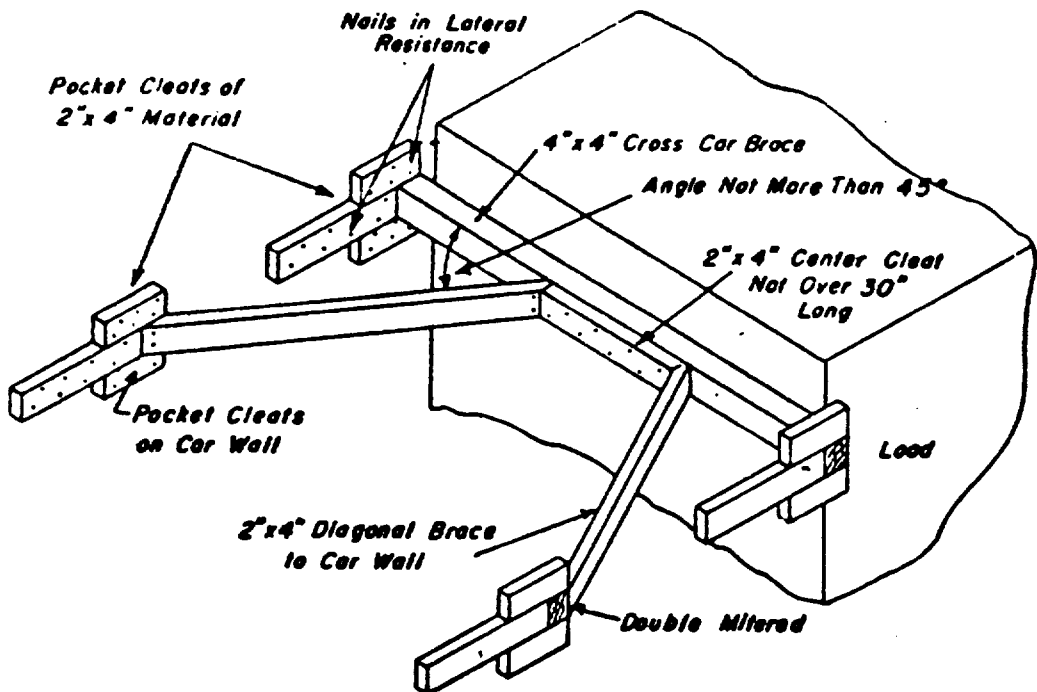


Figure 5. Nails in lateral resistance for diagonal bracing to side walls.

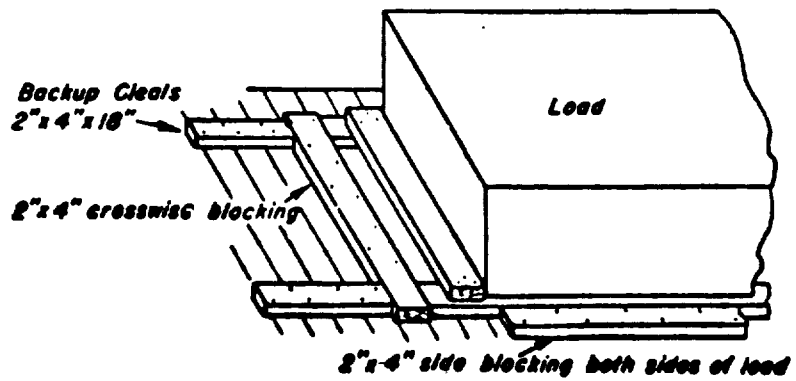


Figure 6. Floor blocking.

(2) Crosswise floor blocking, as shown in figure 3, should not be of less than 2-inch by 4-inch or 2-inch by 6-inch material. It should extend the full width of the boxed or crated article against which it bears.

(3) Cross car bracing should be large enough to hold the load in position in the car properly. Crosswise bracing members that are not reinforced should be placed with the narrow face against the load to utilize the maximum strength of the member, as shown in figure 7.

Table 1. Standard Thicknesses for Yard Lumber

Nominal thickness rough lumber (in.)	Actual thickness SIS* or S2S* (in.)
1 x 4	¾ x 3 ½
2 x 4	1 ½ x 3 ½
2 x 5	1 ½ x 4 ½
2 x 6	1 ½ x 5 ½
3 x 4	2 ½ x 3 ½
3 x 6	2 ½ x 5 ½
4 x 6	3 ½ x 5 ½

\*Surfaced one side or surfaced two sides

**Table 2. Species of Wood Most Commonly Used For Bracing**

Soft woods	Medium woods	Hard woods
Cedar	Douglas Fir	Ash
Chestnut	Hemlock	Beech
Cottonwood	Maple	Elm
Fir, Alpine	Larch	Hickory
Fir, Balsam	Pine (Northern Carolina)	Maple (Hard)
Fir, White	Pine (Southern Yellow)	Oak
Pine, Jack	Ash	
Pine, White		
Spruce		
Poplar		

**Table 3. Soft and Medium Woods (Standard Sizes)**

Medium woods (in.)	Soft woods (in.)
Size 3/8 x 1 1/4 (Lath)	Size 3/8 x 1 1/4 (Lath)
Size 1/2 x 4	Size 3/4 x 4
Size 1 x 2	Size 1/4 x 2
Size 1 x 3	Size 1/4 x 3
Size 1 x 4	Size 1/4 x 4
Size 1 x 6	Size 1/4 x 6
Size 2 x 2	Size 2 x 2 1/2
Size 2 x 3	Size 2 1/2 x 3
Size 2 x 4	Size 2 1/2 x 4
Size 2 x 6	Size 2 1/2 x 6
Size 3 x 4	Size 4 x 4
Size 4 x 4	Size 4 x 5
Size 4 x 6	Size 5 x 6
Size 6 x 6	Size 6 x 7
Size 6 x 8	Size 7 x 8

**Table 4. Cement-Coated Nails and Round Wire Spikes**

Size	Cement-coated nails		Round wire spikes	
	Length (in.)	Gauge No.	Length (in.)	Gauge No. or size (in.)
10d*	2 7/8	11	3	6
12d	3 1/8	10	3 1/4	6
16d	3 1/4	9	3 1/2	5
20d	3 3/4	7	4	4
30d	4 1/4	6	4 1/2	3
40d	4 3/4	5	5	2
50d	5 1/4	4	5 1/2	1
60d	5 3/4	3	6	1
7 in.			7	5/16 in.
8 in.			8	3/8 in.
9 in.			9	3/8 in.
10 in.			10	3/8 in.
12 in.			12	3/8 in.

\*d-Penny

(4) In order to reinforce cross car bracing, diagonal braces extending from the cross brace to the car walls are used to supplement the strength of the cross brace. This forms what is known as a K brace as shown in figure 5.

Another adaptation of the K brace is shown in figure 8. In this example, a single K brace reinforces two cross braces.

(5) The reinforcement of cross car bracing to car floors can be provided by the use of diagonal bracing to the car floor as shown in figure 9. The bracing must not be applied at an angle greater than 45 degrees with the car floor.

It is desirable that the cross brace be positioned at a point approximately one-third down from the top of the load. Table 6 shows the minimum length of diagonal braces in relation to height of cross brace above car floor.

(6) Knee braces should be used to prevent dislodgment or bowing of floor diagonals and should be applied at right angles to the floor diagonals, as shown in figure 9.

(7) Top bracing will be found desirable in many instances to prevent upward movement of a load. The security of this type of bracing is dependent upon the proper application of pocket cleats. Two methods of top bracing are shown in figure 10. Diagonal reinforcement is used for heavy loads. However, the top ends of these diagonals should never be placed at the intersection of the roof and side walls of the car, but should be backed up with cleats and the diagonal braces.

(8) Bracing used to prevent top-heavy articles from falling or tipping over in transit should be placed at a point approximately opposite the upper third of the article. This type of bracing is commonly referred to as collar bracing and is shown in figures 11 and 12. Figure 11 shows two types of machines, A and B. Type A is of solid cast iron base construction and should be blocked against the skid members as shown.

Type B, which is a leg-type construction, must not be blocked crosswise against the ends of the skid members.

(9) When commodities in containers are loaded in more than one layer, filler boards should be used to provide an even base for the containers in the upper layers. Fillers must be of sound material at least 1-inch thick to carry the weight of the load, and must be placed lengthwise in the car. To hold these fillers securely in place, a crosswise board of 2-inch x 4-inch material should be securely nailed to each lengthwise filler board. When the load is rigidly braced, this unit can then be held in position by means of cleats affixed to the cars walls, as shown in figure 13.

(10) Location of the inside blocking should be marked on the outside of the container in order that the car loader can determine where to apply blocking.

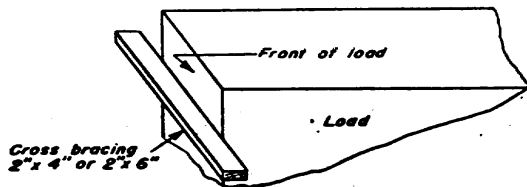
(11) Incomplete layers in shipments should be avoided whenever possible. However, when incomplete layers have to be loaded, crosswise bracing as shown in figures 5 and 14, should be used. Such cross braces must be secured to car walls with pocket cleats, as shown in figure 15.



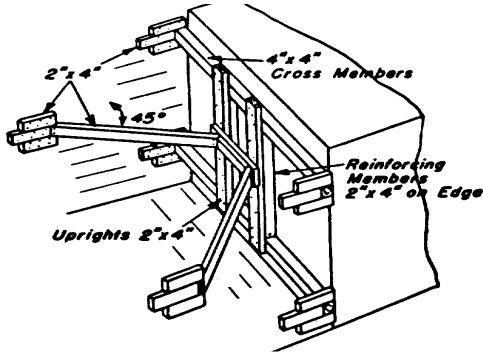
**Table 5. Sizes of Nails, Spikes, and Bolts for Various Thicknesses of Material**

Thickness of material (rough lumber) holding head of nail or spike (in.)	Thickness of material (rough lumber) holding point of nail(in.)					
	1	2	3	4	5	6
1	6d* 8d**	10d 12d**	16d	16d	16d	16d
2		16d	20d 30d	40d 50d	40d 60d	40d 60d
3		30d Bolt	40d 60d	60d 7-in. Spike	7-in. Spike	8-in. Spike
4		Bolt	Bolt	Bolt or 7-in. Spike	Bolt or 7-in. Spike	Bolt or 7-in. Spike
5		Bolt	Bolt	Bolt	Bolt or 9-in. Spike	Bolt or 10-in. Spike
6		Bolt	Bolt	Spike Bolt	Spike Bolt	Bolt or 10-in. Spike

\*d-Penny  
\*\*Nails clinched



**Figure 7. Cross car bracing.**



**Figure 8. Single K brace reinforcing cross braces.**

Cross bracing can also be secured in position, as shown in figure 16.

(12) When the lading does not completely fill the car crosswise, various forms of construction for side or center bracing to prevent move-

**Table 6. Length of Diagonals to Car Floor**

Height of application of diagonal brace to cross brace or load above car floor		Minimum length of diagonal brace required	
(ft)	(in.)	(ft)	(in.)
1	0	1	6
1	6	2	3
2	0	3	0
2	6	3	6
3	0	4	3
3	6	5	0
4	0	5	9
4	6	6	6
5	0	7	3
5	6	7	9
6	0	8	6

ment of lading can be used. Some examples are shown in figures 17, 18, 19, and 20.

*d. Gates.*

(1) Gates are structures used to fill the lengthwise space in a car not occupied by the lading, or to segregate the lading. Gates are designated according to types, such as end gates, divisional or intermediate gates, and center gates.

(2) End gates, shown in figure 21, should be used when commodities in fiberboard containers or light crates are stowed in cars equipped with unlined corrugated steel ends so as to provide a smooth surface for the lading. End gates can also be used at one or both ends of the car to take up lengthwise space in lieu of a center gate, if the shipper desires to use a through load.

(3) Divisional gates, as shown in figures 22, 23, and 24, are used to secure separate units in the load or to segregate different types of containers or commodities. These gates should be held in position by means of blocking secured to

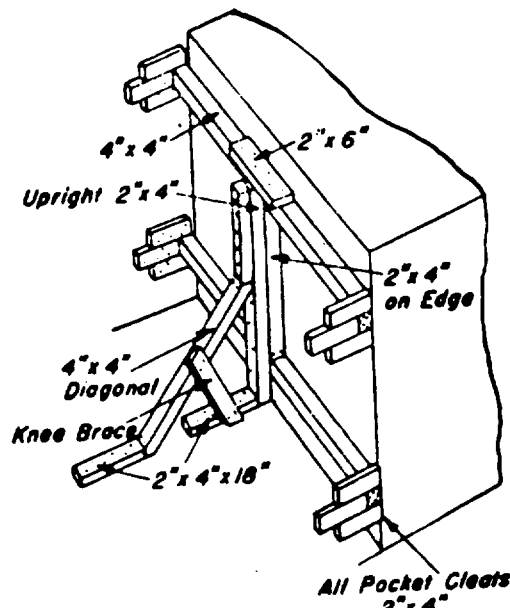


Figure 9. Floor diagonals.

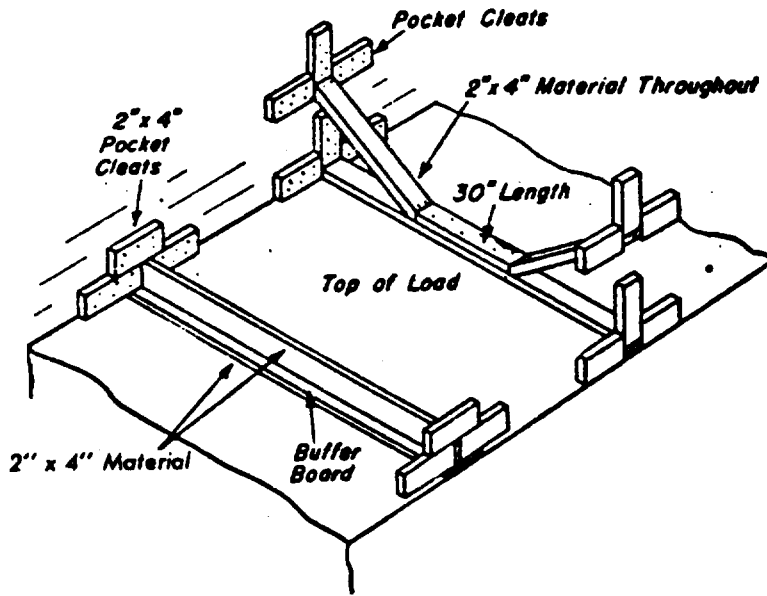


Figure 10. Top hold-down bracing.

the car walls, as shown in figure 23. Care should be taken to protect load from cleats.

(4) Center gates are used to take up the space in the doorway area of the car to prevent a shift in the load and also to permit the ready removal of lading. Figure 25 shows a center gate placed in the space in the load in the doorway area. When a large space is left in the doorway area, blocking and bracing as shown in figures 26 and 27 should be used to secure the lading in position within the car.

(5) When the lading extends into the doorway area, it can be retained in position by securing the crosswise bracing to the doorway protection boards. Either 2-inch x 4-inch, 2-inch x 6-inch, or 4-inch x 4-inch material should be used, as shown in figures 28 and 29.

e. Doorway Protection.

(1) Doorways of cars containing rough freight that is not liable to be damaged by contact with the ends of doorway boards can be protected as shown in figure 30.

(2) When freight liable to be damaged by contact with ends of doorway bracing, such as fiber boxes, bags, or wrapped commodities, is loaded, the doorway protection boards must be set flush with door posts and car lining. Figure 31 shows the application of flush doorway protection in cars with wooden door posts. The construction shown

in figures 32 and 33 should be used in cars with steel-jacketed doorposts.

(3) The spacing of the face members of the doorway protection depends upon the size of the containers or of the individual articles. These boards must be spaced on the uprights so that each member, except the top member, is in contact with two layers of containers, as shown in figure 34.

(4) Doorway protection in the form of steel straps can be used. When perforated steel straps are used, they should not be less than 1/4 inch x 0.020 inch, and when solid steel straps are used, they should not be less than 3/4 inch x 0.028 inch. Steel straps should be tensioned and sealed as shown in figures 35 and 36.

(5) One steel strap should be placed opposite each layer of cargo and sheets of fiberboard, or several thicknesses of heavy paper must be placed over the anchor plates. Large sheets of fiberboard should be placed between the lading and the metal bands, as shown in figure 35. For very heavy freight, it is recommended that 1 1/4 inch x 0.035-inch metal strap be used.

*f. Bracing by Means of Steel Straps.*

(1) With the metal tie method of bracing, metal ties in the form of high tension flat steel

straps or round wires are used in lieu of wood bracing. Two distinct methods are used; namely, the "floating load" and the "anchored load." The number, size, and strength of steel straps required under these methods of loading vary depending upon the weight and dimensions of the commodity loaded and are identified in the various specific commodity AAR pamphlets. However; in no case should steel straps having a joint strength of less than 2,000 pounds be used.

(2) The anchored load provides rigid bracing of the lading by use of metal ties secured to the car walls with anchor plates. Anchor plates must be properly threaded, as shown in figure 37, before being fastened to the car walls. They must be securely nailed to the car post in the car wall, as shown in figure 38, and must be not less than 3 feet back from the face of the load. When round metal ties are used, they must be secured to a car post in the car wall, as shown in figure 39. If the lading comes in contact with the anchor plates, the anchor plates must be covered with fiberboard or several thicknesses of heavy paper. When two or more metal ties are used, they should be tensioned and sealed simultaneously, so as to place the load in a uniform position.

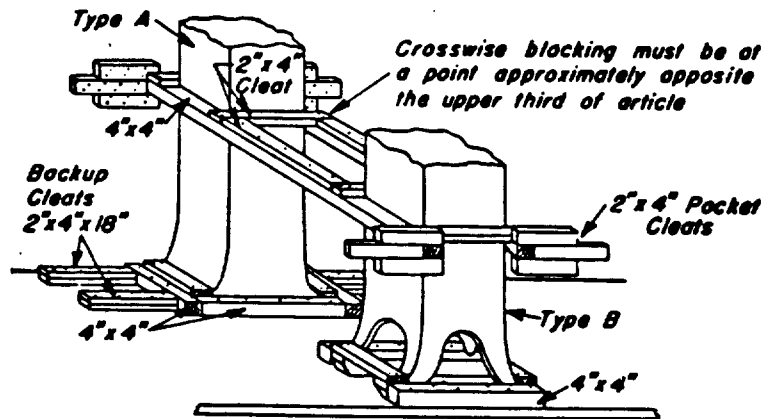


Figure 11. Bracing top-heavy articles-machinery.

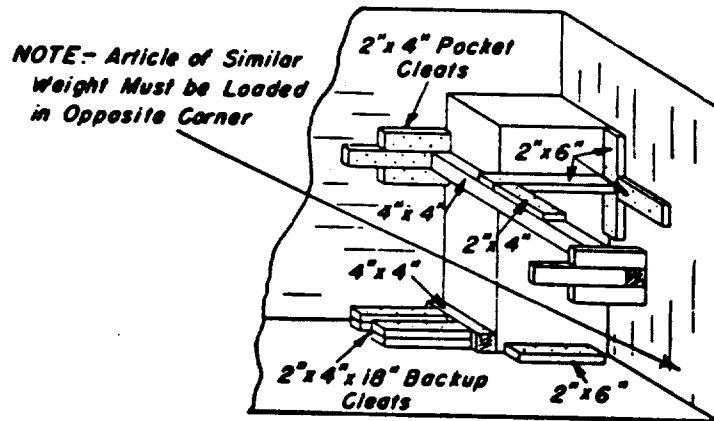


Figure 12. Bracing top-heavy articles containers.

(3) Corner or gate protection must be provided to prevent damage to the lading due to pressure of the steel straps. See figure 40 for corner protection.

(4) The floating load method is adaptable to many commodities, such as crated articles and commodities in barrels. The principle involved consists of tying the lading into two compact units with spaces in the doorway area and at each end of the car, which allow the load to move, thereby reducing shocks to the lading.

Steel straps may be placed around the sides or over the top and under the load. Since the lading is permitted to move, it is important that the car selected for loading has smooth floors and sides and is free from projections on which the lading may snag. Metals straps may be run horizontally or diagonally around the load, as shown in figure 40. In figure 41 the steel straps are shown applied lengthwise over and under the unit. Proper protection must be provided at corners

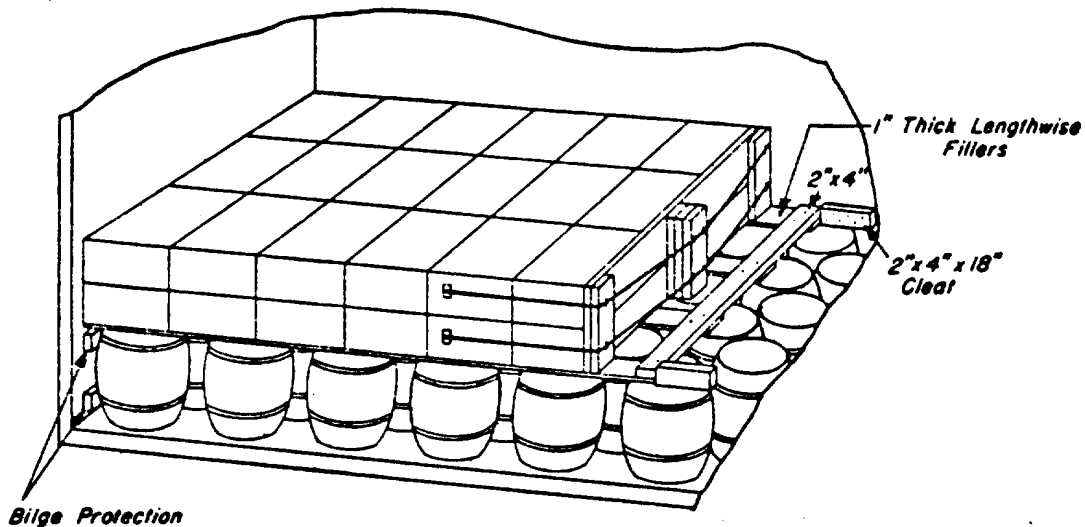


Figure 13. Fillers between layers. Rigidly braced load.

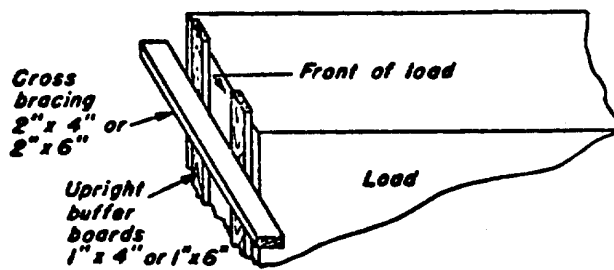
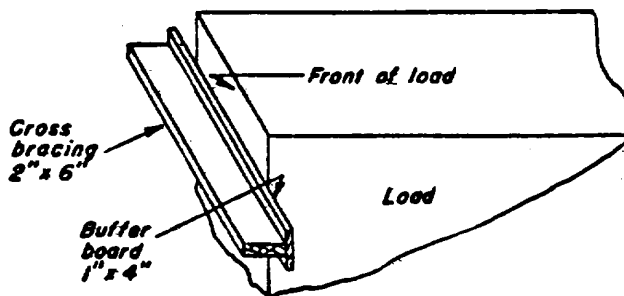


Figure 14. Cross bracing.

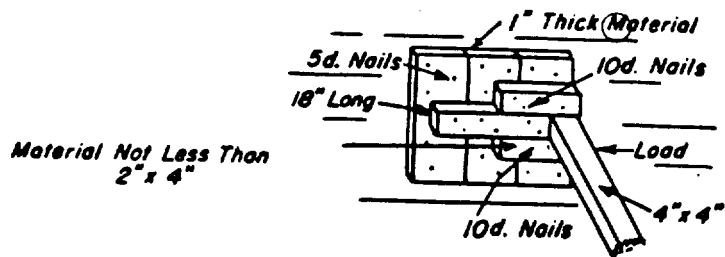
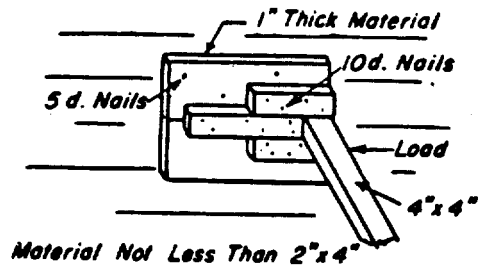
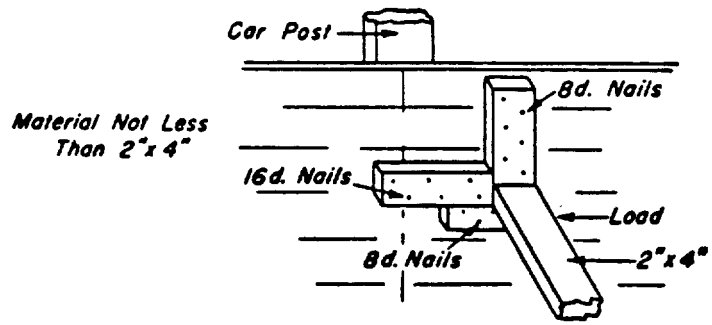


Figure 15. Pocket cleats.

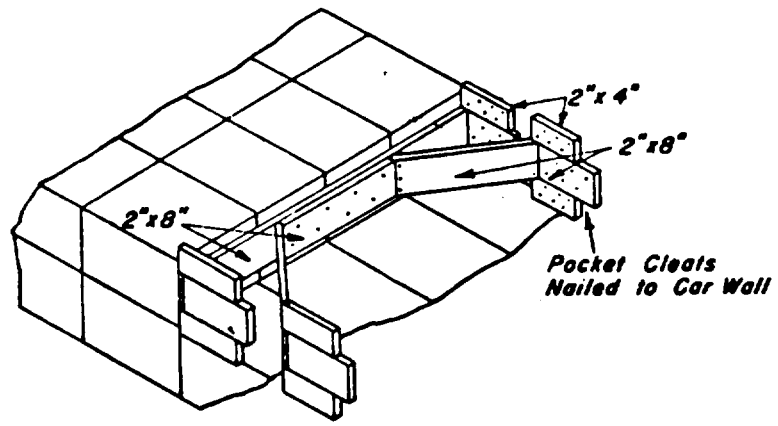


Figure 16. Incomplete layer bracing.

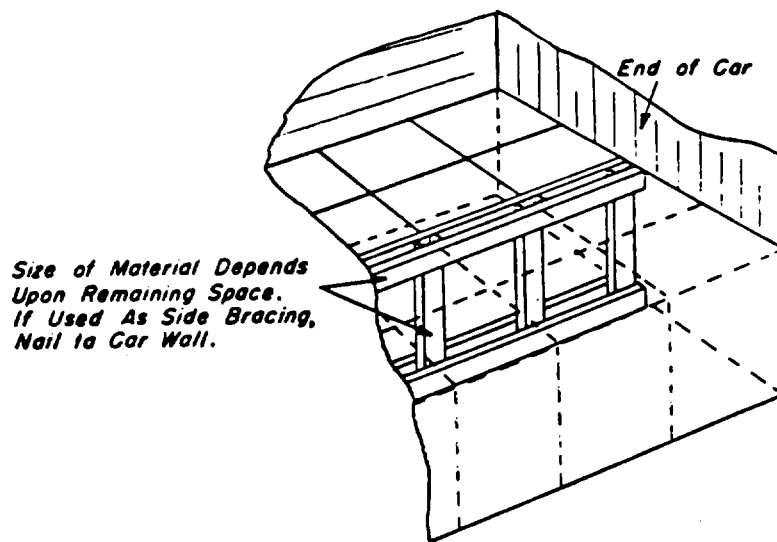


Figure 17. Side or center bracing.

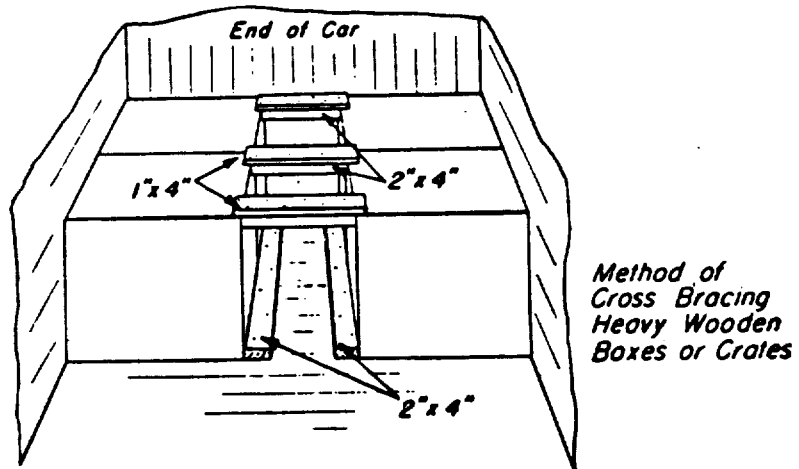


Figure 18. Method of cross bracing heavy wooden boxes.

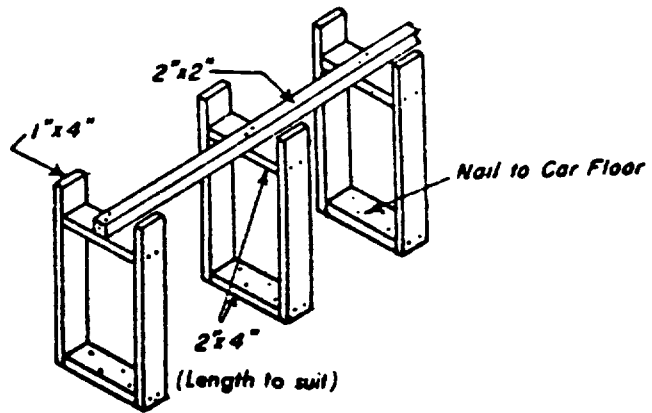


Figure 19. Side or center bracing to fill cross car voids.

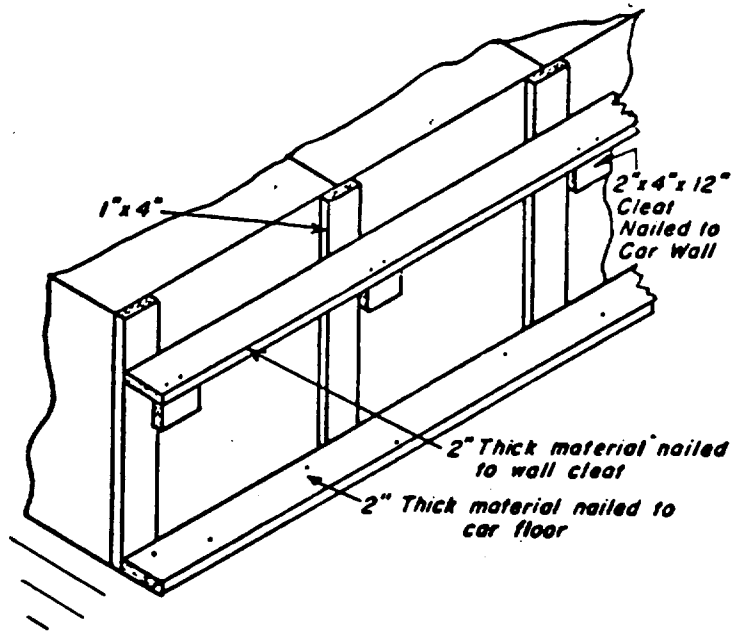


Figure 20. Side bracing.

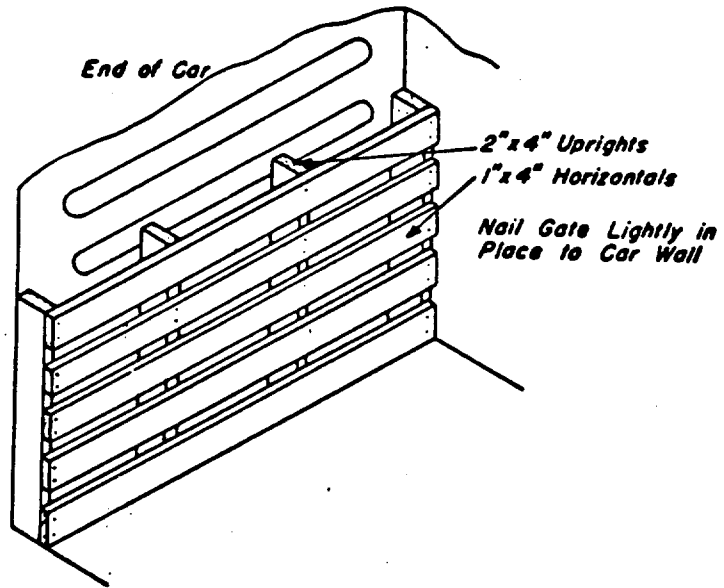


Figure 21. End gate.



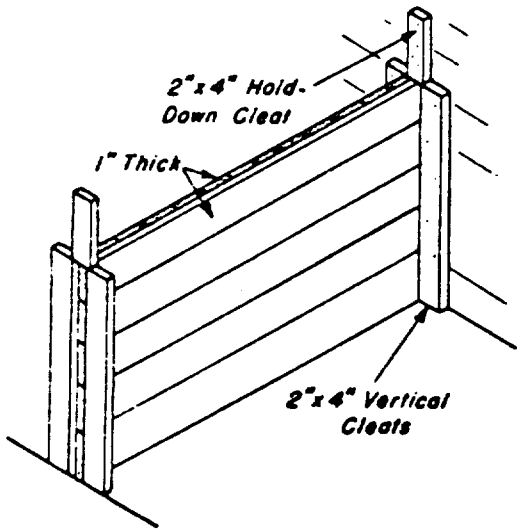


Figure 22. Divisional gate held in place by vertical cleats.

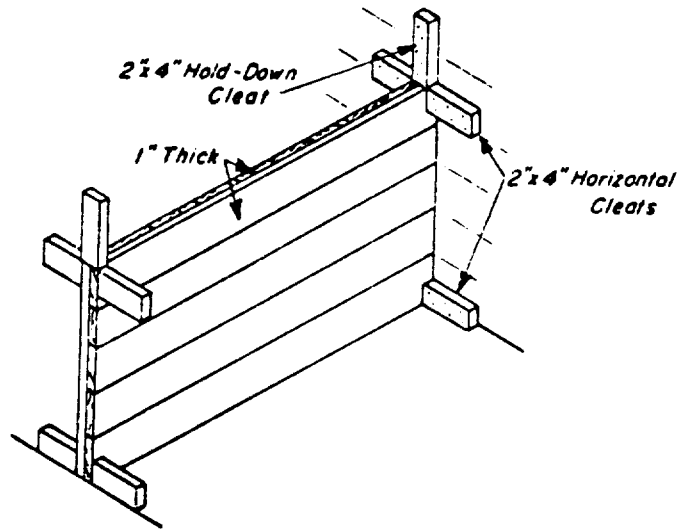


Figure 23. Divisional gate held in place by horizontal cleats.

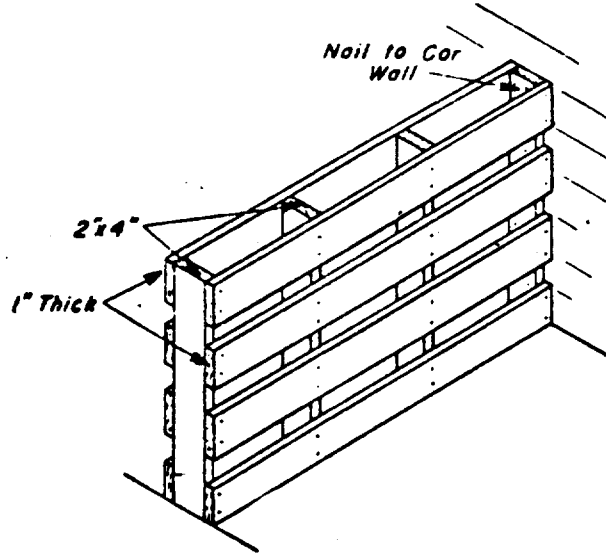


Figure 24. Divisional gate nailed to car wall.

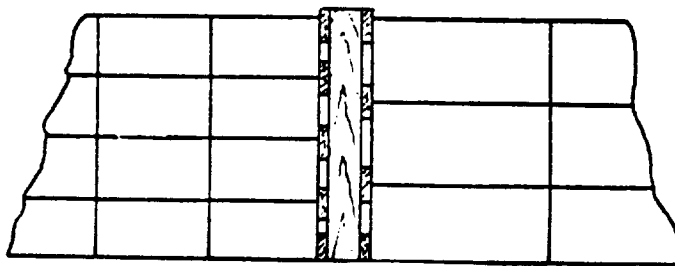


Figure 25. Side elevation of double faced gate.

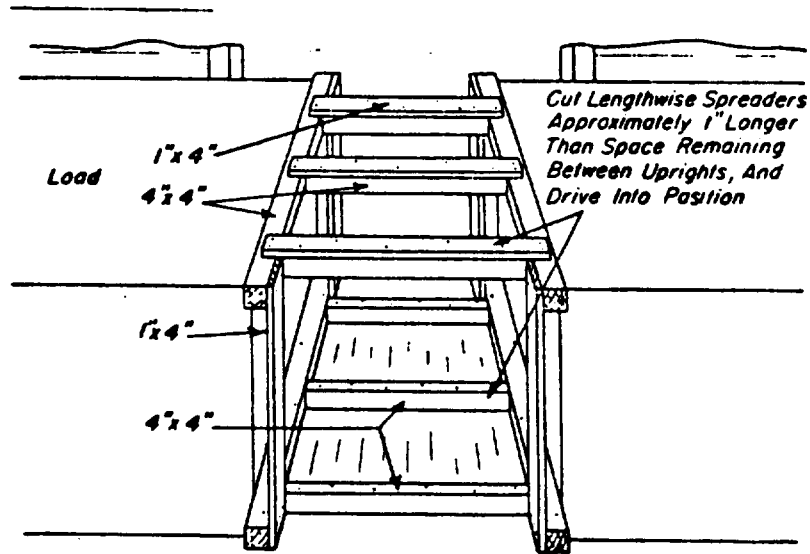


Figure 26. Center gate.

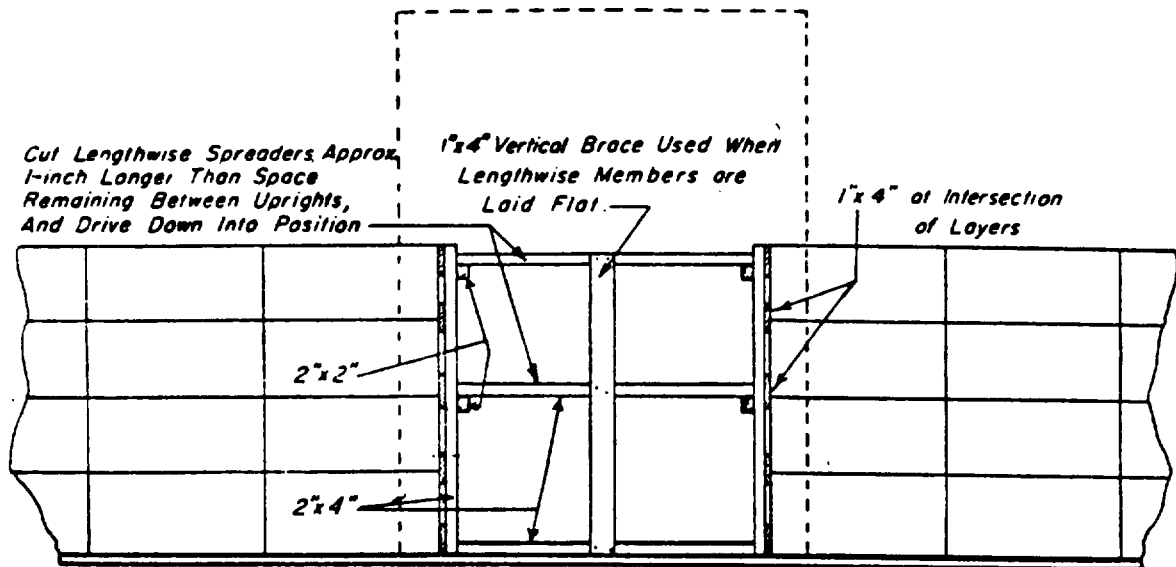


Figure 27. Use of vertical brace when long span exists to prevent buckling of lengthwise spreaders.

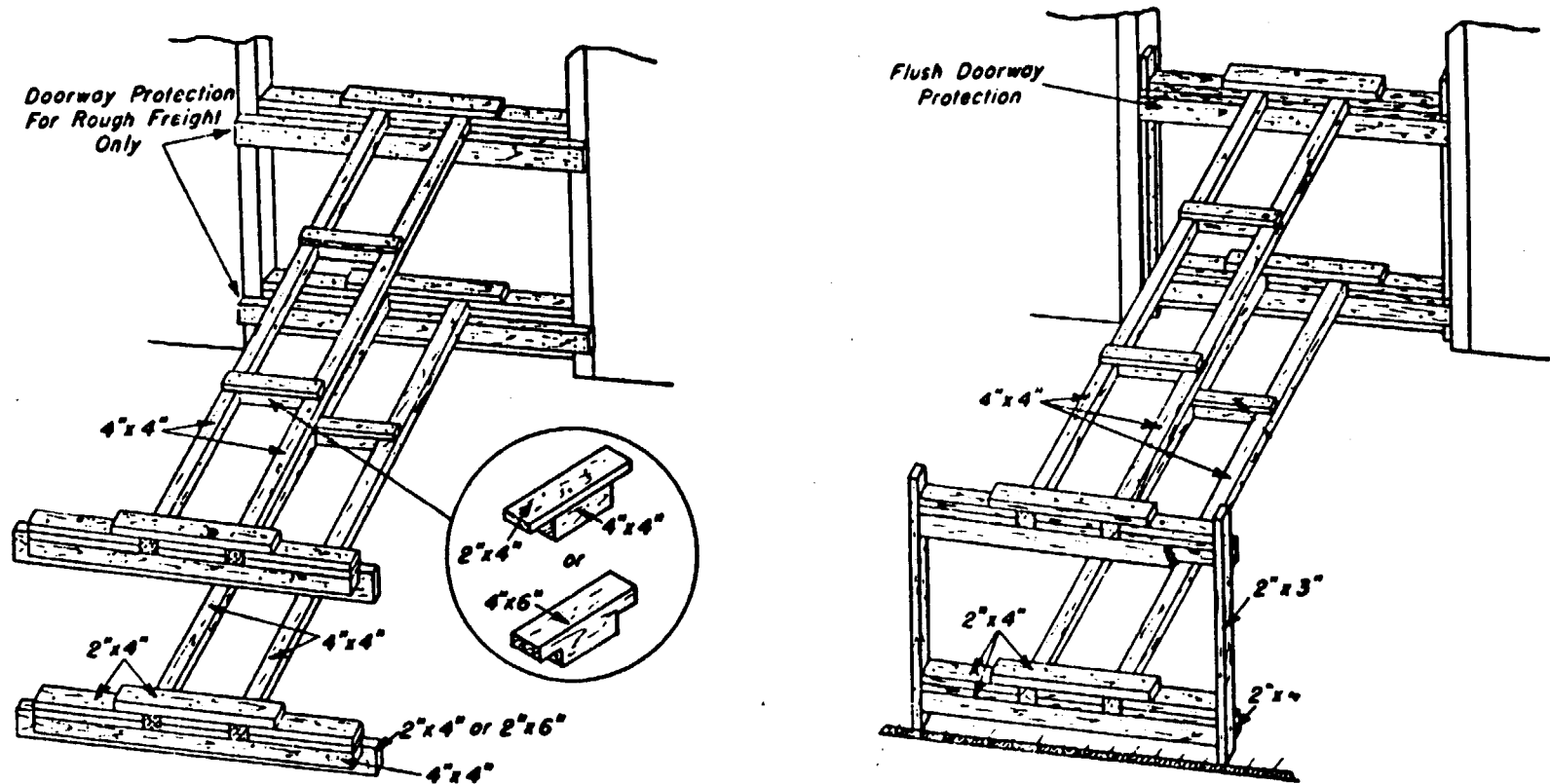


Figure 28. Bracing affixed to doorway protection.

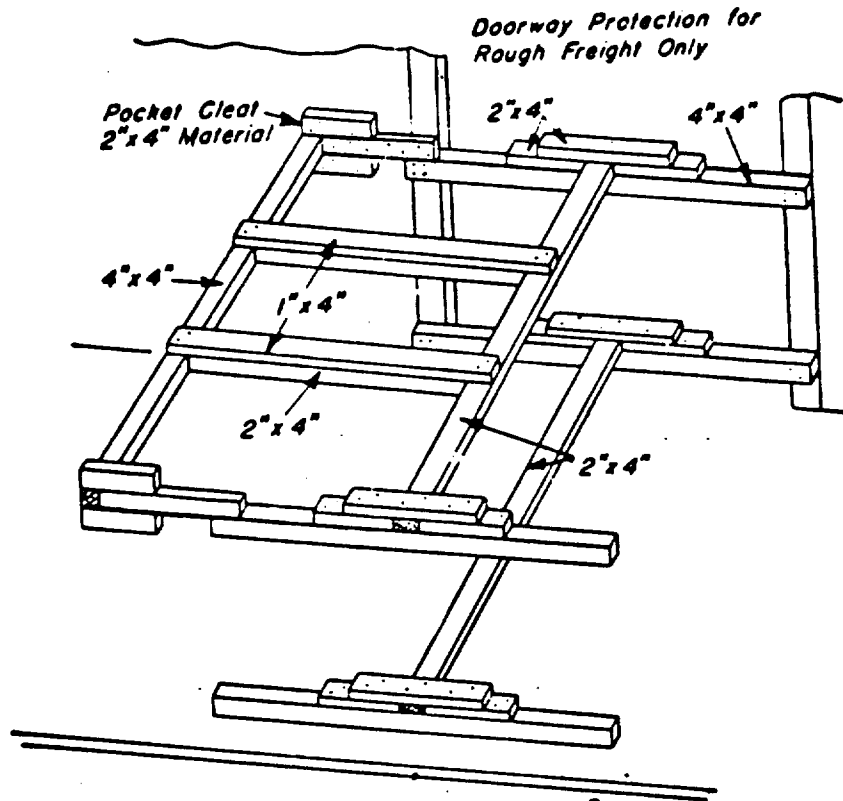
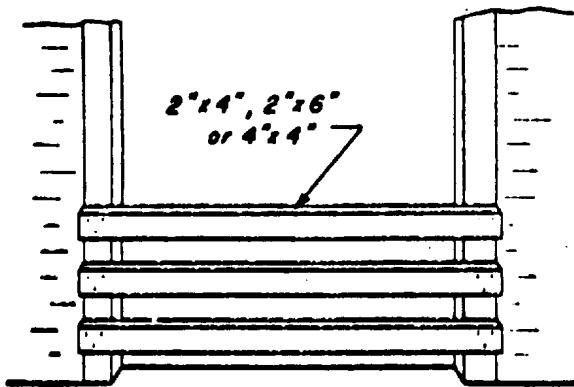
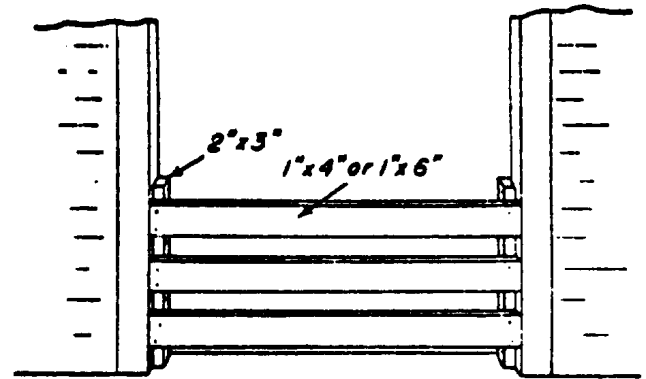


Figure 29. Bracing affixed to doorway protection and side walls.



*Doorway Protection for Rough  
Freight Only*

Figure 30. Doorway protection for rough freight only.



*Flush Doorway Protection for  
Cars With Wooden Doorposts*

Figure 31. Flush doorway protection for cars with wooden door posts.

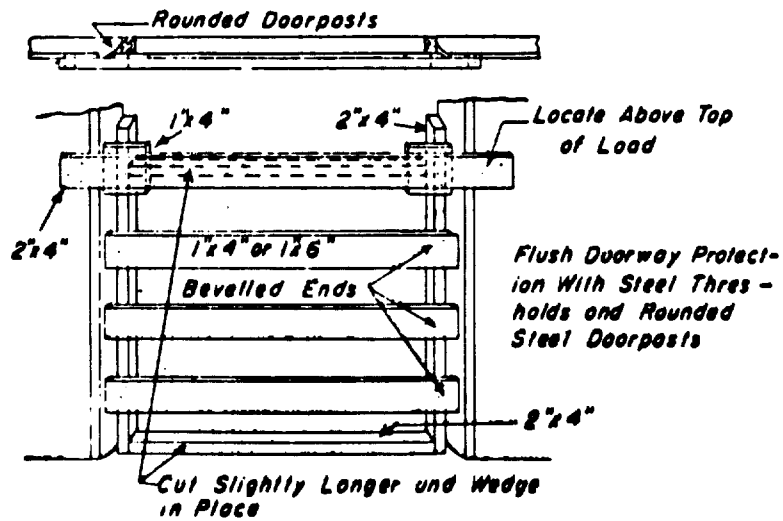


Figure 32. Flush doorway protection.

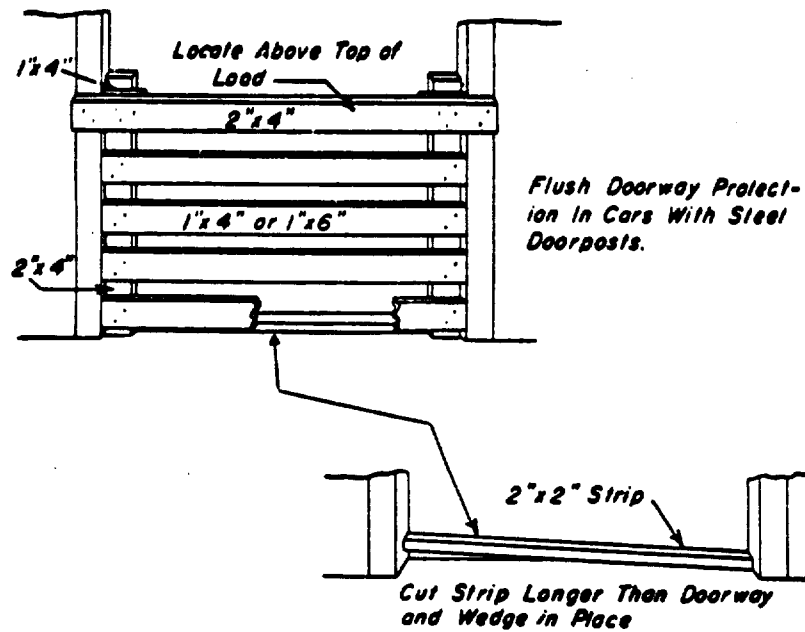
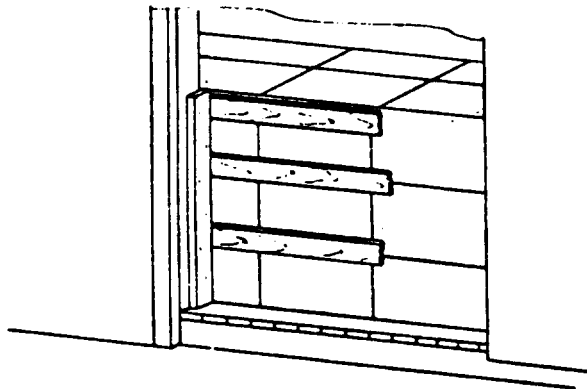


Figure 33. Flush doorway protection in care with steel door posts.



*Space Face Members of Intersection of Layers*

Figure 34. Doorway protection.

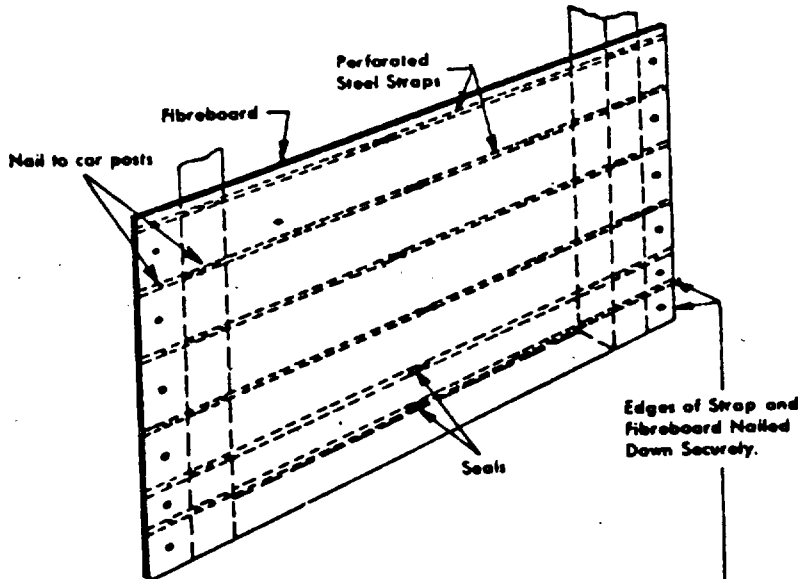


Figure 35. Steel strap reinforced fiberboard doorway protection.

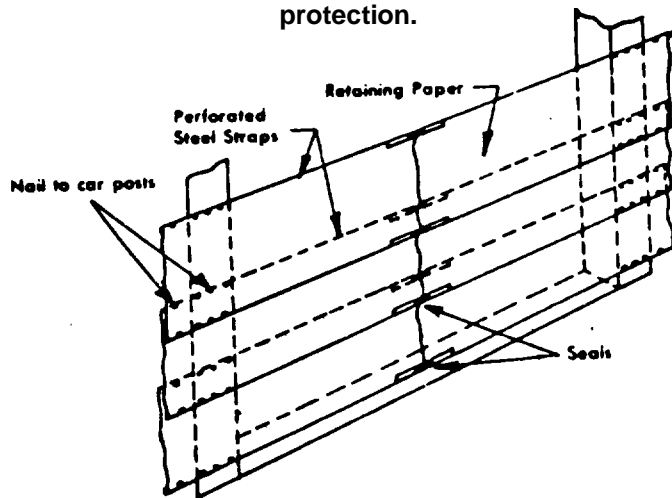
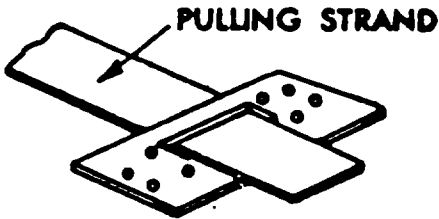
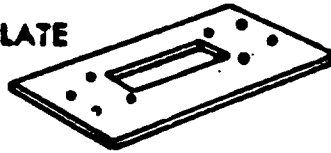
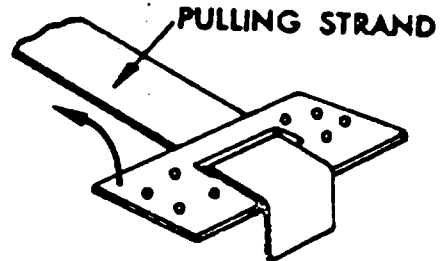


Figure 36. Steel strap reinforced paper or fiberboard retaining strip doorway protection.

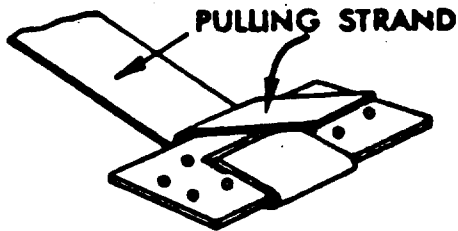
**ANCHOR PLATE**



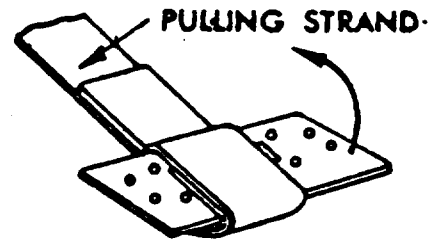
**2**  
**SLIDE STRAP THROUGH ANCHOR PLATE SLOT**



**3**  
**BEND STRAP, THEN FOLD PLATE BACK ON PULLING STRAND**

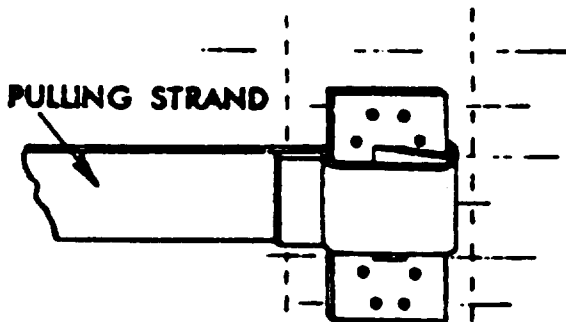


**4**  
**COMPLETE FIRST FOLD, THEN START SECOND FOLD**



**5**  
**COMPLETING SECOND FOLD**

**DO NOT OVER-HAMMER STRAP WHEN FOLDING. THIS WEAKENS OR MAY FRACTURE THE METAL.**



**ANCHOR PLATE PROPERLY THREADED AND APPLIED TO CAR POST WITH PULLING STRAND BETWEEN ANCHOR PLATE AND CAR POST. NAIL ANCHOR PLATE TO CAR POST WITH CORRECT SIZE, CEMENT COATED OR CHEMICALLY ETCHED NAILS. DO NOT USE DRIVE SCREWS, BARBED OR ANNULAR RING NAILS.**

Figure 37. Steel straps.

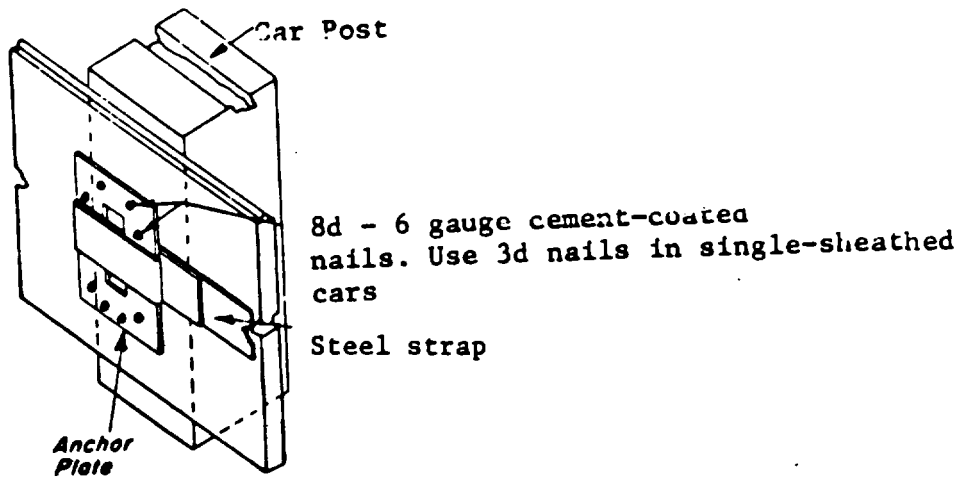


Figure 38. Application of flat steel straps to car wall.

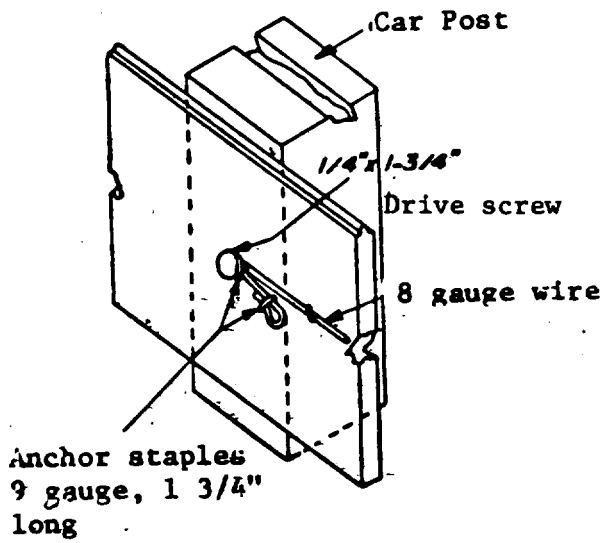


Figure 39. Application of round wire to car wall.

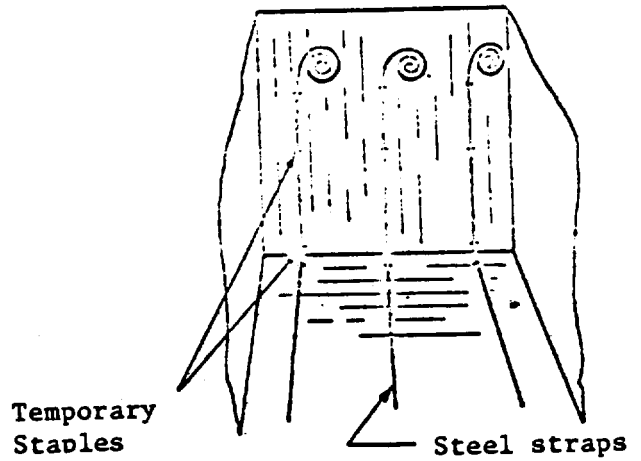


Figure 40. Steel straps applied over and under load.

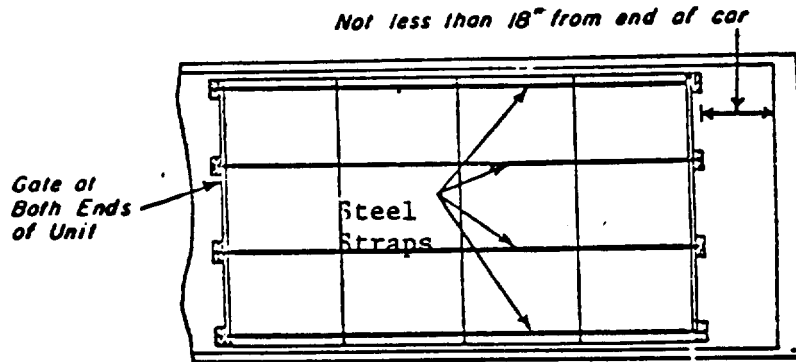


Figure 41. Plan view showing application of lengthwise steel straps over and under load.



or top and bottom edges of load to prevent damage. When the load does not occupy the full width of the car, the vacant space should be equally distributed on each side of the load. Floor blocking must be applied to each side of the load in order to prevent lateral creeping.

(5) Semifloating loads are prepared in the same manner as "floating loads" except that the units are loaded against the end walls of the car with a space left in the doorway area.

**3. General Rules**

(As contained in AAR circular 42-D or supplements thereto)

*Rule 1. Inspection and Selection of Cars.*

(A) Cars must be inspected either before they are placed for loading or at the loading point to see that they are in suitable condition to carry the loads safely to destination.

(B) (1) Cars for loading heavy or concentrated weight must be inspected by the originating carrier either before they are placed for loading or at loading point to see that they are in suitable condition to carry the loads to destination.

(2) When ordering cars for loading heavy or concentrated commodities, shippers have the responsibility of notifying serving carriers of this purpose and of not loading any cars not inspected per Rule I(BX1).

(3) Cars selected for loading commodities of heavy or concentrated weight must meet the following requirements: wooden floors of boxcars built after January 1957, or rebuilt after 1 January 1964, must be at least 2M inches thick and must have at least 3-inch full length steel Z sections weighing 6.7 pounds per foot, or three steel I sections weighing 5.7 pounds per foot (or other sections of equivalent strength) as longitudinal floor stringers on each side between center and side sills. Effective January 1975, the above requirement will apply to all boxcars in interchange. However, on special cars having a different type of underframe, two longitudinal floor stringers on each side between center and side sills may be used, provided the overall strength of the floor is not less than that of a floor with three stringers as specified in the foregoing.

*Rule 2. Clearance, Side Bearing, Loaded Cars.*

There must be sufficient clearance between the side bearings to permit free curvature of the trucks.

*Rule 3. Maximum Load Weight.*

(A) The weight of a load on the car must not exceed the load limit stenciled on the car.

(B) The weight of load on one truck must not exceed one-half of the load limit stenciled on the car. In case of doubt, the weight of the load must be verified by weighing.

(C) The percentages of stenciled load limits shown below must not be exceeded for loads located between truck centers, unless the car owner has designated by note in the Official Equipment Register (app B) that these percentages may be changed (fig 42).

<i>Length of load</i>	<i>Percentage of load limit</i>
10 feet to 20 feet	50
20 feet to 24 feet	60
24 feet to truck centers	75
Truck centers to full length of car	100

(D) The following percent of load limits shall apply for staggered double-door cars built prior to 1 January 1966, except as provided in (A) and (B).

Inside length 40 feet 20 feet long 40 percent

Inside length 50 feet 25 feet long 40 percent

(E) Weight of material loaded in either end of the car between the truck centers and ends of car must not exceed 15 percent of the stenciled load limit for cars built prior to 1 January 1966, and 25 percent for cars built subsequent to 1 January 1966.

(F) When length of load is less than the distance between truck centers and the load is not located in the center of the car, the center of the load must not be nearer to either truck center than shown below:

When load weight is reduced to	}	50 percent	Any place between truck centers.
		60 percent	1/6 the distance between truck centers.
		66.6 percent	1/6 the distance between truck centers.
		75 percent	1/6 the distance between truck centers.
		87 percent	1/6 the distance between truck centers.
		90 percent	9/20 the distance between truck centers.

(G) When the load is lapped or staggered between truck centers and covers about the full length of the car, and the weight of the load does not exceed the stenciled nominal capacity of the car, Rule 3(C) need not apply.

(H) When crosswise bearing pieces are used, the distance between the outside bearing pieces (center to center) must exceed the minimum distances specified in above Rules (C) and (D) for that percentage of the stenciled load limit being loaded.

(I) The distance between crosswise bearing pieces (center to center) under lapped or staggered loads must be placed so as to prevent excessive concentration of weight over specified spaces shown in above Rules (C) and (D).

(J) Bearing pieces, lengthwise of car, extending beyond the lading, may be used in order to distribute the weight of the lading over a greater area. In such cases "length of bearing pieces" is substituted for "length of load" in above Rules (C) and (D). Bearing pieces must definitely be of suitable strength and continuous.

*Rule 4. Distribution of Weight Crosswise of Car.*

(A) The load must be located so that the weight along both sides of car is about equal for the entire length of the load.

(B) When the load is of such character that it cannot be placed so as to obtain equal distribution of weight crosswise of car, suitable ballast, properly secured, must be used to equalize the weight.

(C) Unless otherwise specified in the closed car loading pamphlets covering methods for loading, blocking, and bracing carload shipments of individual commodities, where vacant space across the car, between piles, and between load and car sides exceeds a total of 18 inches, the load must be secured so as to prevent moving or tipping towards sides of car.

(D) (1) Cars equipped with adjustable side wall fillers at diagonally opposite sides of car, for filling void space crosswise of car, may be used providing such space does not exceed 15 inches.

(2) Cars equipped with full side wall fillers at both sides in both ends of car, for filling void space crosswise of car, may be used provided such space does not exceed 6 inches from each side of car.

*Rule 5. Loading, Blocking, and Bracing.*

(A) All lading must be secured so that it will not come in contact with side doors, or roll or shift in transit, either crosswise or lengthwise, except that a shift of lading is permissible when the load is secured as a floating unit. In

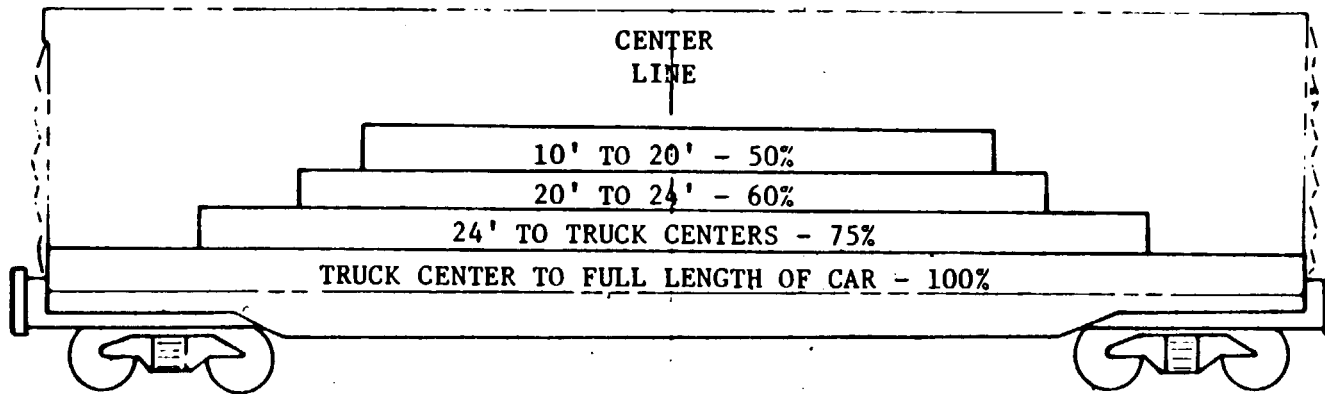


Figure 42. Weight concentration percentages.

such instances the recommendation affecting individual commodities must be adhered to.

(B) All lumber used for blocking and bracing must be of sound material and free from defects that impair its strength or interfere with proper nailing.

(C) Machines and other items having a high center of gravity or narrow base must be secured to prevent them from tipping over in transit.

(D) When lift trucks are used for loading and unloading, suitable steel plates must be placed in the car to prevent damage to the car floor.

(E) High-tension steel straps or wires securing the load must be machine tensioned and sealed or twist tied.

(F) Metal fillers, such as corner guards or plates, sufficient to provide a suitable radius, must be used to protect straps and wires at all points on lading having sharp edges. They must be applied so as to prevent displacement.

(G) Steel straps must be attached to car walls in accordance with the methods prescribed for the individual commodities in order to reduce to a minimum the possibility of anchor plates pulling loose or steel straps shearing.

(H) The threads on rods or bolts used as bracing or blocking, or in connection therewith, must be nicked immediately behind single or double nuts to insure nuts remain in their original position. When only one or two threads extend beyond nuts, the ends of the rods or bolts must be riveted over. This is not required when nut locks or lock nuts are used.

**Note**

**Lockwashers are not acceptable substitutes.**

(I) Where high-tension steel straps or high-tension wires are specified in the detailed rules, they may be substituted for each other, if of equal load strength, provided all the other items used to secure the load are equal in number and strength.

(J) The proper combination of steel strap or wire and sealing tools must be used to provide the minimum joint strength for sizes listed in tables 1, 2, and 3.

(K) Tables 7, 8, 9, and 10 identify the characteristics of high-tension straps, high-tension wire, common annealed wire, and rods and bolts respectively.

*Rule 6. Doorway Protection.*

Doorway protection must be provided when there is a possibility of lading falling or rolling out the doorway or coming in contact with side doors. Door openings must be protected with adequately secured wooden doorway protection or metal ties of sufficient strength and number.

**Table 7. Characteristics of High - Tension Straps**

Width and thickness (in.)	Minimum joint strength (lb.)
3/8 x 0.050	1,700
3/4 x 0.022	1,780
3/4 x 0.025	1,780
3/4 x 0.028	1,780
3/4 x 0.031	2,125
3/4 x 0.035	2,125
3/4 x 0.044	2,975
3/4 x 0.050	2,975
1 1/4 x 0.031	3,400
1 1/4 x 0.035	3,400
1 1/4 x 0.044	5,100
1 1/4 x 0.050	5,100
2 x 0.044	8,075
2 x 0.050	8,075

**Table 8. Characteristics of High - Tension Wire**

Gauge	Diameter (in.)	Minimum joint strength (lb.)
8	0.1620	1,700
10	0.1350	1,700
11%	0.1130	1,150
12	0.1055	1,080

**Table 9. Characteristics of Common Annealed Wire**

Gauge	Diameter (in.)	Minimum breaking strength (lb.)
3	0.2500	2,200
7	0.1875	1,100
8	0.1719	950
9	0.1562	800
11	0.1250	500

**Table 10. Characteristics of Rods and Bolts**

Diameter (in.)	Minimum breaking strength (lb.)
1/2	5,200
5/8	8,100
3/4	11,700
7/8	16,200
1	21,100
1 1/8	25,800
1 1/4	32,800
1 3/8	88,600
1 1/2	46,900

**4. Loading of Carload Shipments of Barrels, Drums, or Kegs in Closed Railcars.**

*a. General Information.*

(1) Shippers must observe carrier's rules regulating the safe loading of freight and protection of equipment (Rule 27, Section 3, Uniform Freight Classification) (app A).

(2) Cars selected for loading should be clean and have sound floors, roofs, side and end walls, and be free from protruding nails or other projections that might cause damage to the lading.

(3) When the load extends into or through the doorway area or if the contents may move into the doorway area, the doorways must be protected as shown herein.

(4) The use of good sound containers is important. Carefully examine and reinspect containers before loading if any evidence of leakage or previous container damage is detected.

*b. Loading.*

(1) Ends of cars used for loading liquids or semi-liquids in tightly coopered barrels or kegs must be prepared with bilge protection as shown in figure 43, except when the floating unit method is used and other means of bilge protection are provided as described in paragraphs c(8) and c(9), below. The application of this

material prevents contact of the weakest part of the barrels; namely, the bilge, with the car end wall and places contact above and below the bilge, where greater strength in the barrel is present. It also provides two points of contact instead of one.

(2) Load all barrels, tierces, and kegs on end. Tight loading is absolutely necessary. Start the load against the bilge protection, being sure to space the containers properly across the car so that straight crosswise rows will be obtained. When loading by the rigid brace method, the containers at each end of the first row across the car should be placed in the corners of the car touching both the end wall bilge protection and side walls with remaining containers in this row to be equally spaced along the end wall. Nest the second crosswise row of containers in the valleys formed by the containers in the first crosswise row and continue to load alternate rows in this manner. See figure 44. As the bung stave is the weakest stave in a barrel or keg, the containers must be so loaded that the bung stave will not be in contact with adjacent barrels, kegs, wall of car, or blocking members.

(3) Heavily loaded containers in a rigidly braced load must be segregated into multiple units in each end of the car, to distribute the weight and pressure of the load against the divisional and doorway area bracing. Each unit of each layer must be separately braced in position (fig 45, 46, 47, and 48).

(4) Fillers of not less than 1-inch thick material or equivalent must be placed lengthwise of the car on top of the floor layer when a second layer of containers is to be loaded. Similar fillers must be used between subsequent layers (fig 46, 47, and 48). Crosswise end cleats must be nailed to the ends of the filler boards to keep them in line. Bilge protection, as shown in figures 43, 48, and 49, must be affixed to end walls to protect the containers in each layer.

(5) Bilge protection is not required when loading metal drums. Drums should be loaded in nested crosswise rows, as shown in figures 50 and 51.

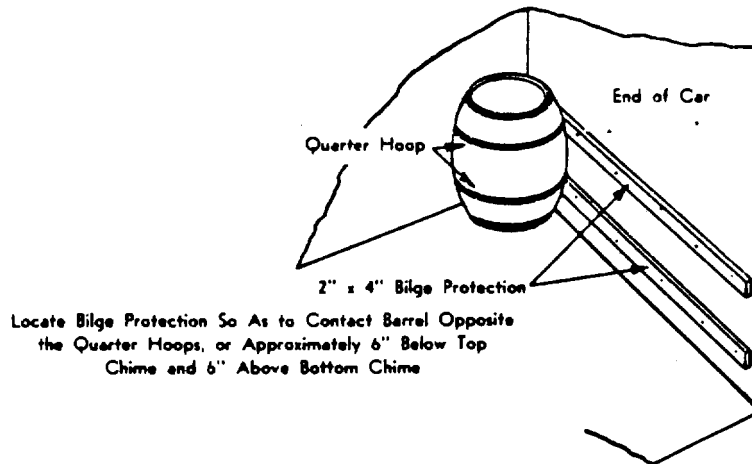


Figure 43. Application of bilge protection.

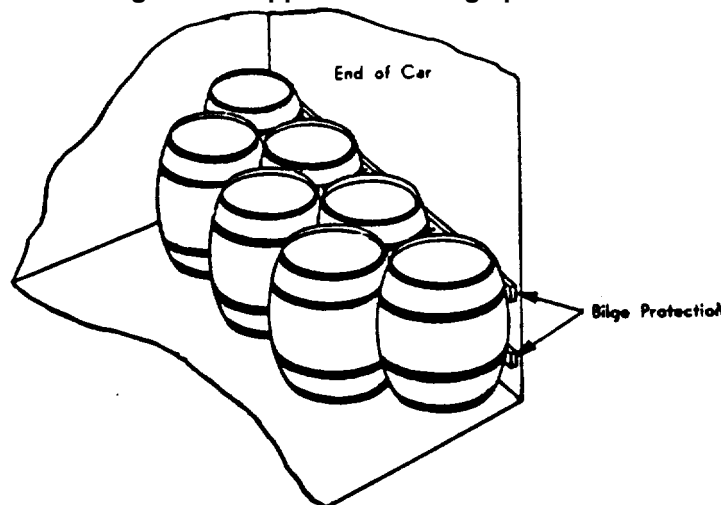


Figure 44. Nesting of crosswise rows.

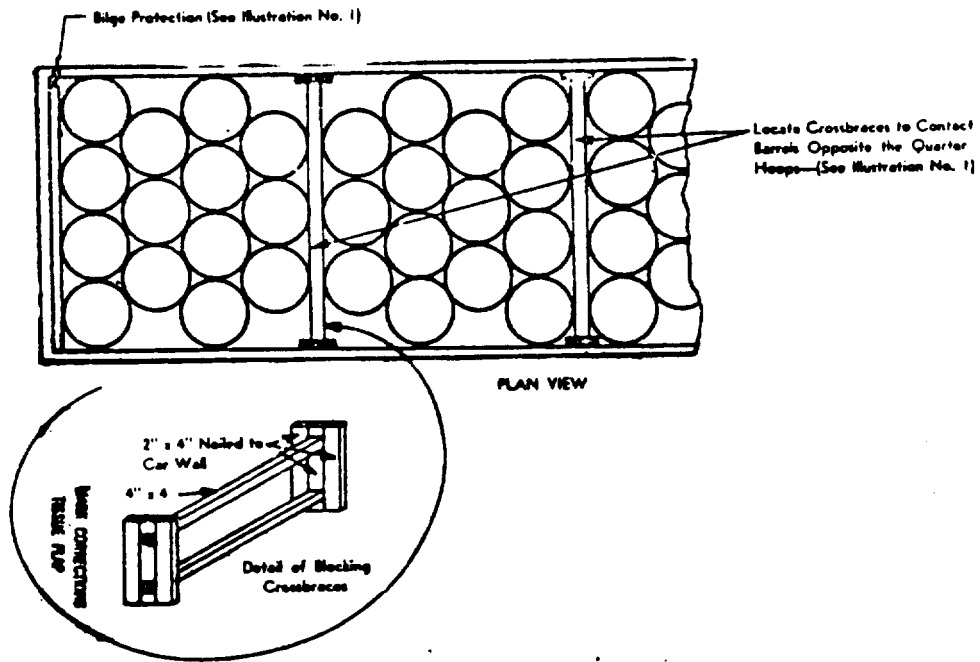


Figure 45. Bracing of units. Heavily loaded containers.

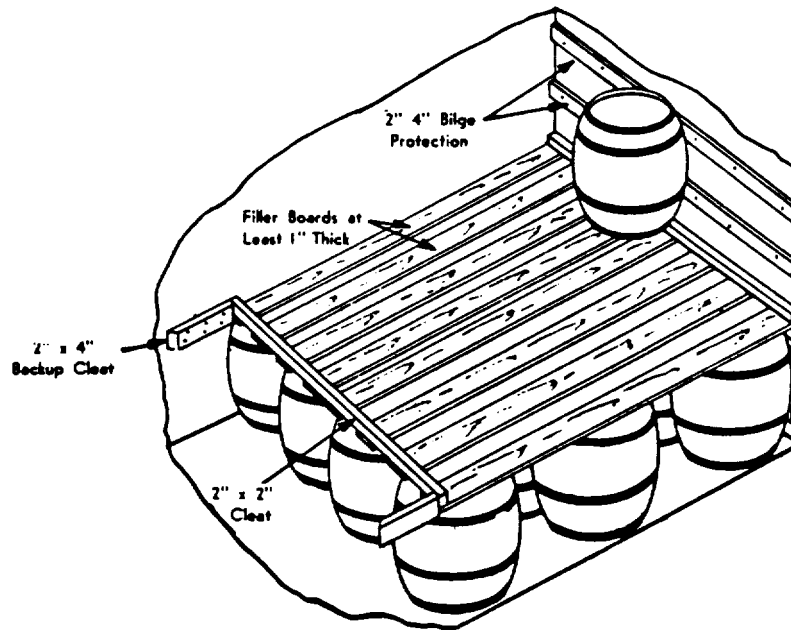


Figure 46. Fillers between layers—rigidly braced load.

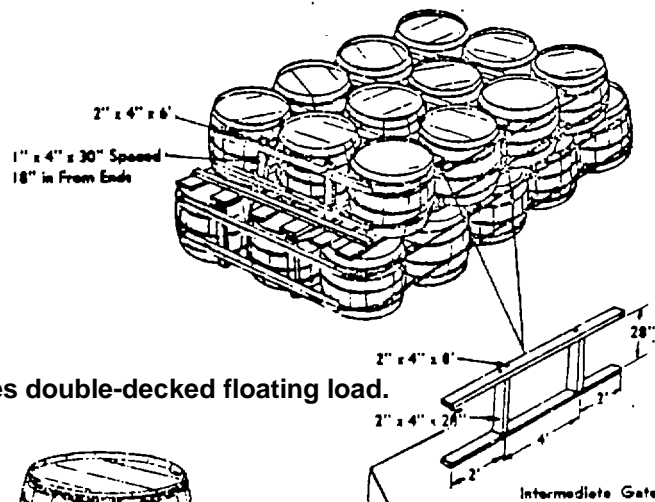


Figure 47. Tierces double-decked floating load.

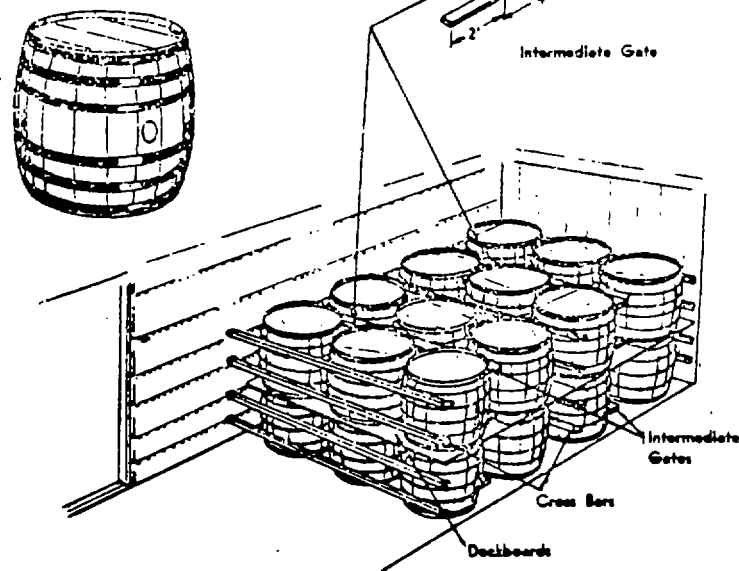


Figure 48. Tierces loaded in equipped cars.

(6) The best method for loading fiberboard drums is by the nested pattern, as shown in figures 52 and 53. The number of drums in the first loaded stack will depend on the diameter of the drums and the width of the car. The maximum number of drums possible should be loaded in the first stack to obtain the most desirable offset pattern shown in figures 52 and 53. Load the second stack in the recesses of the first stack as illustrated.

Variations in sizes of drums may result in patterns of 4-3-4, 6-5-6, 7-7, or 8-7-8. If the drums are large and will not fit five wide across the car as shown in figure 52, then load the drums in the 4-3-4 nested pattern as shown in figure 53. An alternate to this would be the 4-4 (equal number) offset loading pattern, as shown in figure 54.

(7) In each loading plan, the drums must be loaded tightly throughout the car and be forced back into place. Drums in all stacks must be offset, as shown in the figures, in order to maintain two-point contact with adjacent drums. Each stack should be in alignment across the car so that the last stacks of the load in the doorway have a "square front" for proper application of bracing.

(8) It is strongly recommended that only full or complete layers of drums be loaded. A full or complete layer referred to here is a layer from the end walls of the car to the doorway area bracing. If an incomplete layer of drums is loaded, filler material must be placed between the full and incomplete layers. Filler decking is important to maintain alignment and stability of the drums in multi-layer loads and may be of

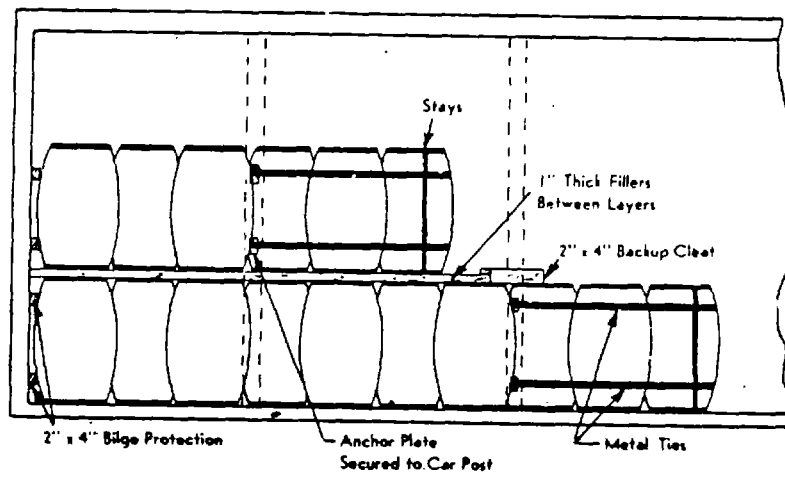
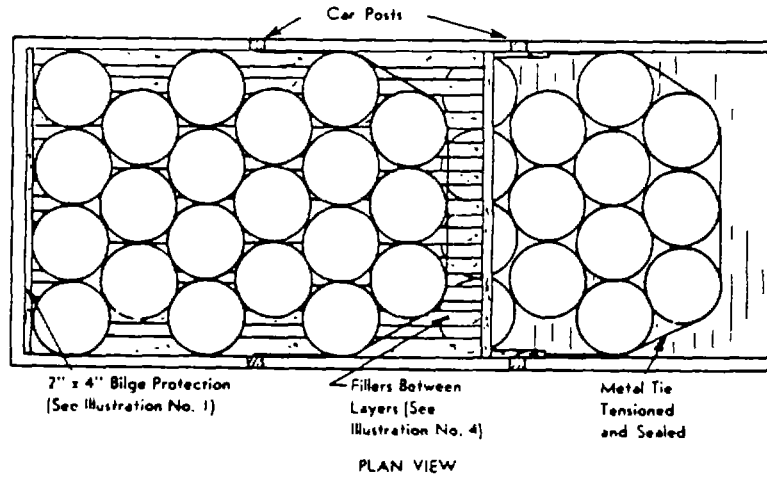


Figure 49. Anchored load with partial layer.

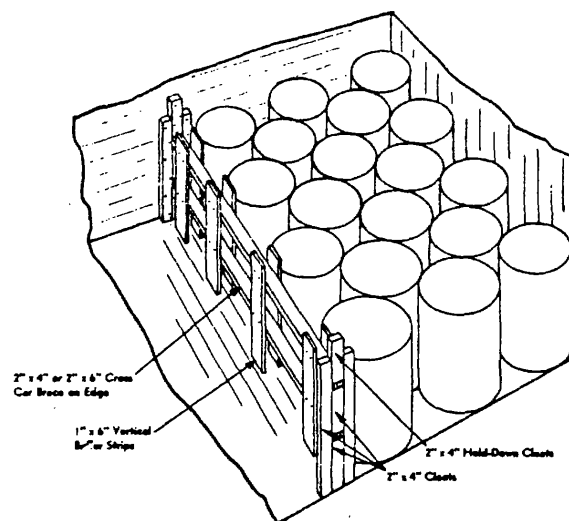
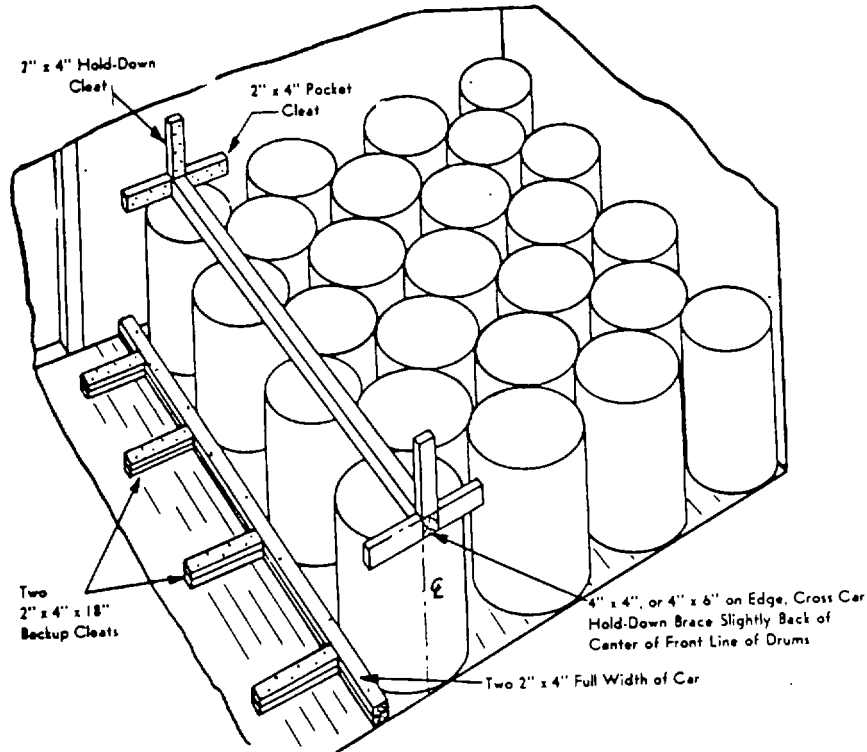


Figure 50. Wood bracing of light-gauge, straight-side metal drums.



**Figure 51. Loading heavy-gauge, heavy-duty drums in one layer only.**

wood or fiberboard. When drums are of the same diameter in both layers, full width sheets of fiberboard may be used for filler material. When different size drums are loaded on top of the floor layer, 1-inch x 3-inch or 1-inch x 4-inch filler boards may be used and so arranged that two boards come in contact with each drum.

*c. Bracing and Blocking.*

(1) A tight compact load is essential in the loading of barrels, drums, and kegs. Each container should be braced and blocked within a car by adjacent containers or by properly applied bracing to prevent movement or dislodgement.

(2) Lading should be braced against movement or dislodgement within a car by use of cross car braces and gates as shown in figures 45, 55, and 56.

(3) Drums should be braced and blocked as specified in (1) above. Single trip or light gauge containers easily damaged by contact with cross car bracing must be protected by application of vertical buffer strips of 1-inch by 6-inch material between the containers and across car bracing, as shown in figure 50. Drums with rolling hoops must be loaded with hoops against sides of adjacent drums and not hoops against hoops.

The hoop to body contact is necessary in preventing the development of lengthwise slack within the load. Crosswise

fillers used under alternate crosswise rows will provide such contact (fig 57). Heavy-gauge, heavy-duty metal drums loaded in one layer only may be blocked and braced as shown in figure 51.

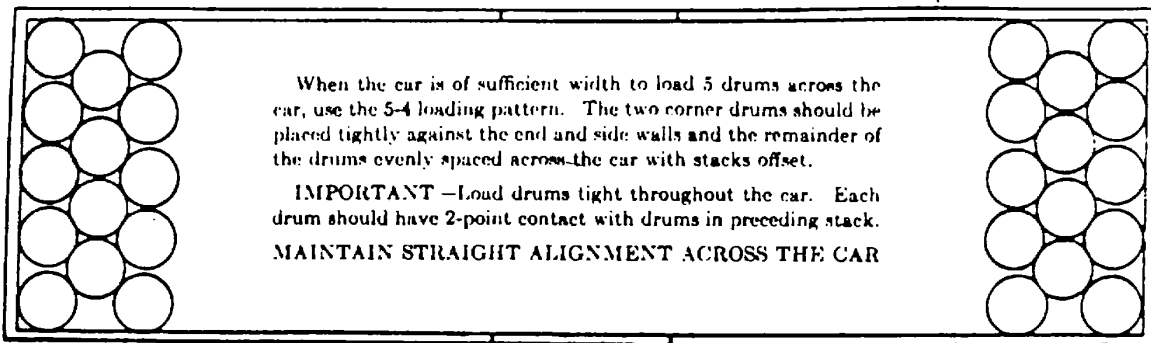
(4) Crosspieces used in gates should be placed with narrow face against gate verticals for maximum strength. See figure 50.

(5) Partial layers should be blocked and braced securely in place with a K brace as shown in figures 56 and 58.

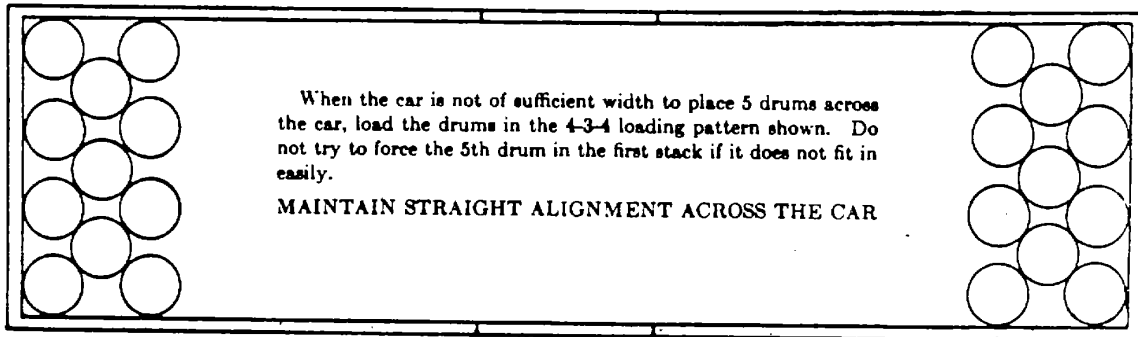
(6) When using the anchor load method, metal ties in the form of flat bands are used for securing gates and the lading within the car in lieu of wood bracing. Flat metal bands must not be less than 1¼ 4 inch by 0.035 inch with a load strength of 4,000 pounds per tie. The containers should be loaded and bilge protection applied as described in b(1) and (2) above. The flat steel straps must be properly threaded through anchor plates as shown in figure 37, after which the anchor plates must be securely nailed to the car post in the car wall, as shown in figure 59.

Figure 60 shows the preparation of a car for the anchored load. Metal or wood stays must be used to keep the straps in proper position at the quarter hoops.

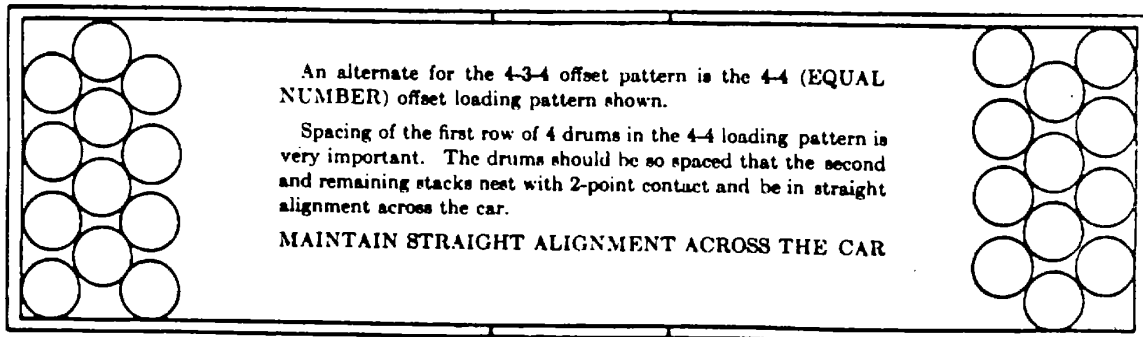




**Figure 52. 5-4-5 Nested loading pattern**



**Figure 53. 4-3-4 Nested loading pattern.**



**Figure 54. 4-4 (equal number) nested pattern.**

(7) Anchors must be located a minimum of 3 feet back from the front face of the load. After the loading is completed, the metal ties must be properly tensioned and sealed with the proper tools for this purpose.

(8) When using the "floating" load method, steel straps are temporarily draped on car sides and end walls prior to loading. Ties must be spaced so as to contact barrels above and below the bilge at the quarter hoops and be held in that position with wood or metal stays. A sufficient number of stays must be used to insure that the steel straps will not drop out of position, thereby causing a loose load.

(9) A floating load must be started 18 inches or more away from the end wall, depending on the number of barrels or drums to be loaded and the floor space required. The barrels or drums are stowed in a nested configuration. Upon completion of loading, the steel straps must be drawn around the unit in each end of the car and tensioned and sealed with the proper tools. It is desirable to tension the straps for each unit at the same time in order to obtain uniform tension. Fillers with cross cleats at each end must be placed between all layers. Ends of the upper layer must be in from the ends of the lower layer a distance of 1½ barrels or drums.

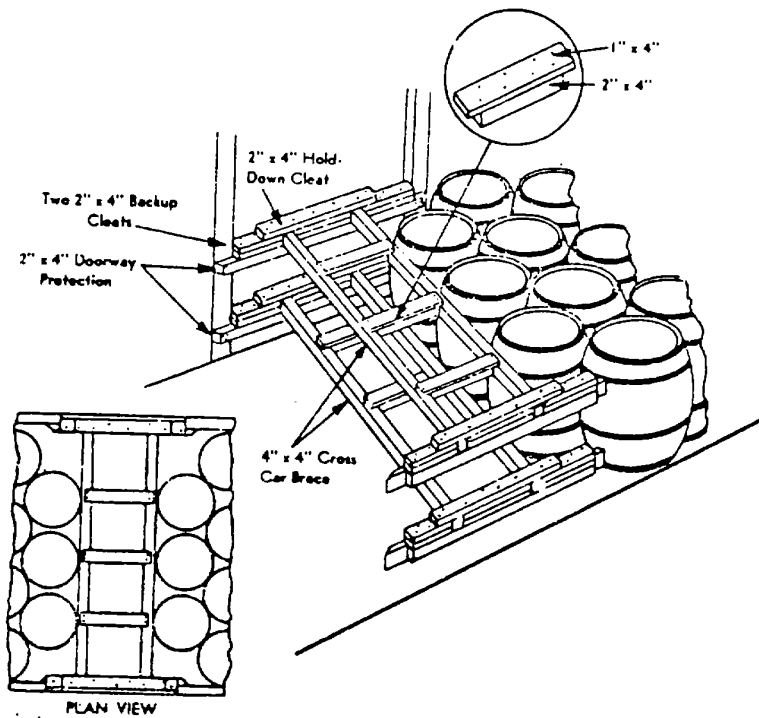


Figure 55. Bracing doorway area.

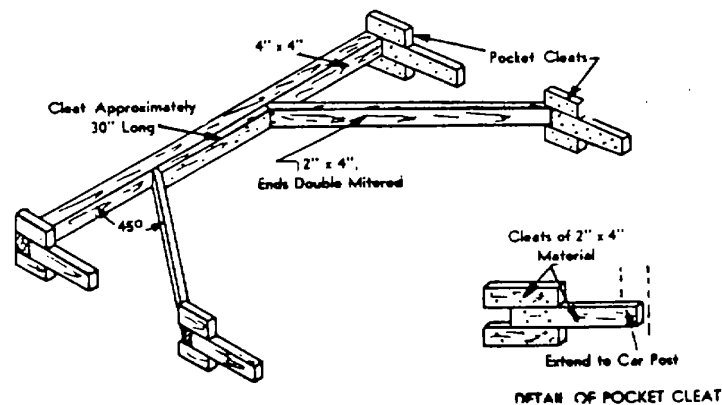


Figure 56. Detail of K brace

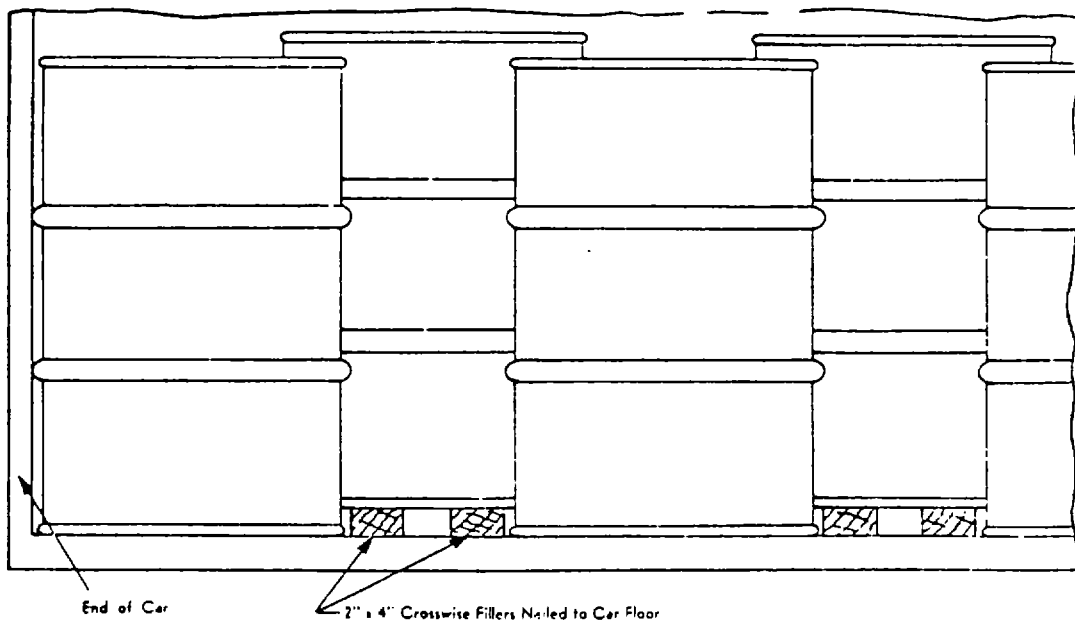
Under no condition should second or subsequent layers be rigidly braced when the floor layer is tied as a floating load. Bilge protection must be used in this method of loading and is applied in the form of gates located at each end of the unit. The horizontal members of the gates contact the barrels at points 6 inches from the chimes and are held in position by two vertical members placed in the voids between the barrels.

#### 5. Fiberboard Containers Loaded by Bonded Block and Palletized Methods

##### a. General Information.

(1) As in all other cases, cars should be cleaned and carefully prepared by removing nails, cleats, straps, anchor plates, and other projections.

(2) The principle of the bonded block method is to build up the load in blocks, in which



**Figure 57. Rigid Braced method of loading metal drums with rolling hoops.**

the containers are bonded together into units by reversing each layer. It is most important that as the containers are stowed in the car, they be firmly pressed back into place and when the doorway is reached that all open space lengthwise of the car be taken up by appropriate means.

(3) Loading should be planned in advance by running a "Guide Row" the full length of the car along one side wall to set up the pattern for the whole load and to determine the amount of lengthwise space required to make a tight load (fig 61). All lengthwise space not occupied by containers must be filled using fiberboard material or wood bulkheads. The face of the wood bulkheads next to containers should be covered with fiberboard, as shown in figure 62. The bonded blocks will not always fill all the lengthwise space in the car. In such cases some of the containers near the doorway area of the Guide Row should be rearranged, placing a stack or two crosswise or lengthwise to fill most of the space as shown in figure 61. Any remaining space should be filled with sheets of fiberboard or knocked down fiberboard containers.

(4) The load should be divided into sections by placing sheets of fiberboard between every second or third block. Full sheets of fiberboard, preferably 80 point solid fiberboard, should always be used between blocks of different size containers, as shown in figures 63 and 64.

(5) There are three basic patterns for bonded block loading, as shown in figures 65, 66, and 67.

(a) Start the block by placing the containers in the floor area crosswise and lengthwise of the car as shown in pattern A, figure 65. In the second layer of the block the position of the containers is reversed. The third layer and

all other odd layers are the same as layer 1, while the even numbered layers are the same as the second layer.

(b) In pattern B, start the block in the floor area as shown in pattern A, figure 66. The second layer is the reverse of the floor layer.

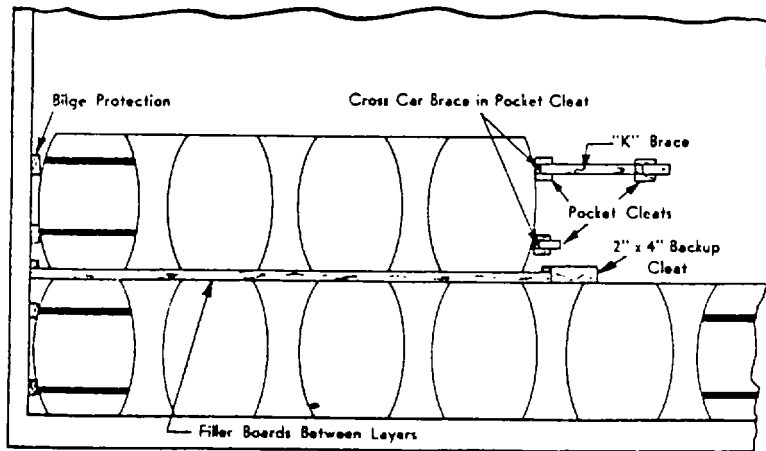
The third layer and all other odd layers are the same as the floor layer and all other even layers are the same as the second layer.

(c) To start pattern C (fig 67) the containers are arranged similar to pattern A with the exception that a pinwheel or chimney is used to take up excess crosswise space. The pinwheel or chimney is reversed from side to side in alternate layers of the block. The third and all other odd layers are the same as the floor layer, and the fourth and all other even layers are the same as the second layer.

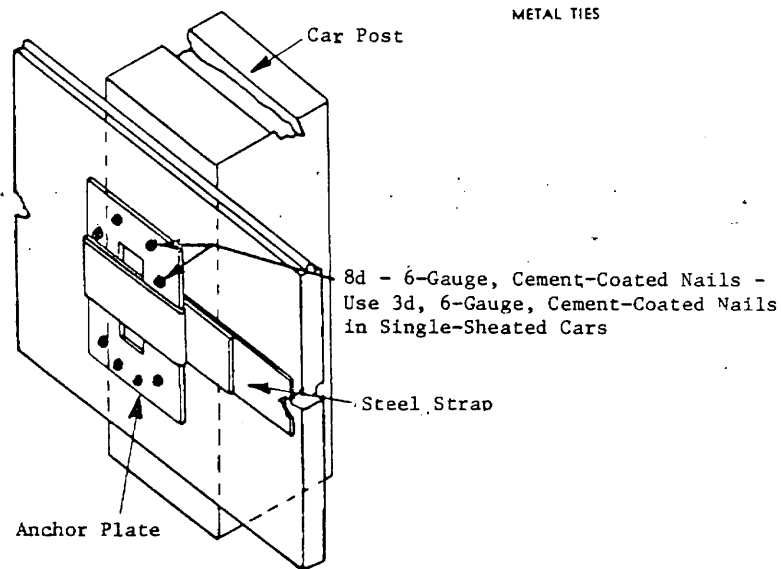
(6) Palletized loads.

(a) Palletizing of packaged goods affords an efficient means of loading and unloading. In order to obtain such efficiencies, however, it is necessary to utilize completely both the lengthwise and crosswise space in the car. This affords the opportunity for maximum load with minimum bracing as shown in figures 68 and 69.

(b) To obtain the best load and stack stability for the units and efficiency in handling operations, the guidelines that follow can be of assistance:



**Figure 58. Bracing of partial layer.**



**Figure 59. Application of flat steel strapping to car wall.**

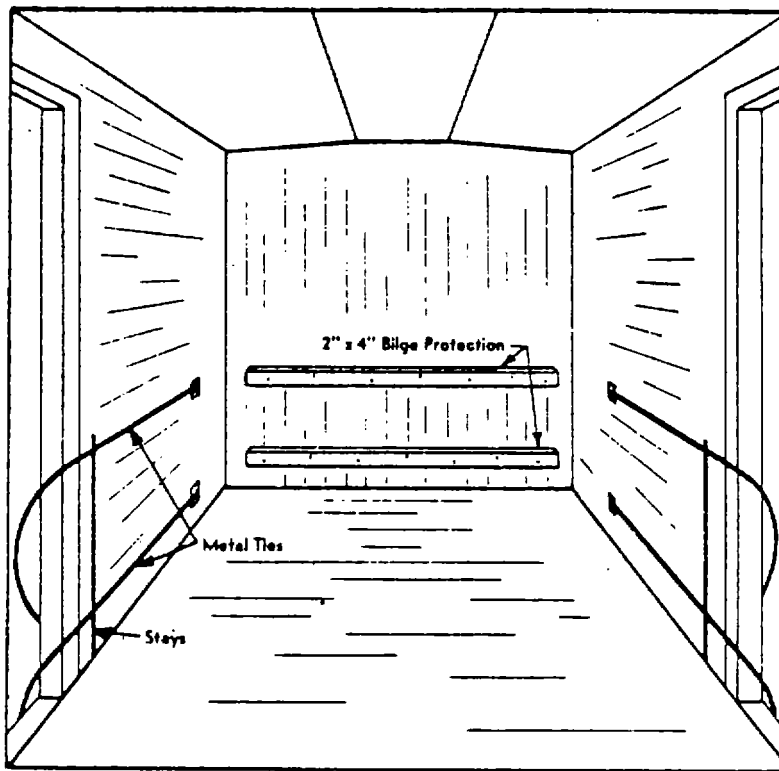
1. Pallet dimensions should be such that they will occupy maximum floor area.
2. Shipping containers on pallets must be stowed by the bonded block method, and containers must be flush with outside edges of pallet deckboards.
3. Vertical scores of palletized containers should maintain good alignment. To accomplish this, containers may be spot glued to pallet deck and to each other or a corrugated fiberboard tube may be used to inclose the palletized unit.
4. Pallet units must be loaded in a straight line lengthwise of the car.

5. When there is any unfilled cross car space, fillers should be used.
6. It is important to use divider sheets between pallet units of different size containers as shown in figures 63, 64, 68, and 69.

**6. Procedures for Handling, Stowing, and Bracing of Mixed Merchandise**

*a. General Information.*

- (1) Most damage in shipments of mixed



**Figure 60. Draping one end of car with steel straps for anchored load.**

freight is caused by adjacent freight, which is, often of an entirely different size, density, and configuration, striking or crushing an item. In addition, the pressure points where two items are in contact are often the weakest parts of the containers. To compound these problems, excess lengthwise and crosswise void spaces often exist due to mixed sizes and shapes.

(2) The following recommendations are general guidelines and should be followed whenever possible when loading mixed cargo in box cars: (a) Evenly distribute the weight of the load from side-to-side and end-to-end of car and to a uniform height of lading insofar as lading permits, as shown in figure 70.

(b) Freight should be stowed in the position and on the surface offering the greatest protection, but still keeping due regard for the weight and character of the packages assembled in building up the load. Heavier lading should be placed in the lower layer and lighter lading in the top layers, as shown in figure 70.

(c) All spaces to the required height of the load should be stowed snugly, fitting packages together to obtain good stowing.

(d) Freight with narrow bases should be loaded lengthwise of the car, as shown in figure 71.

(e) Doorway areas should be stowed in a manner to prevent contact of freight with door or doorposts through use of doorway protection, as shown in figures 72 and 73.

(f) Pails, buckets, and small drums of liquids or solids should be loaded to prevent shift against other lading by use of plywood separators.

(g) Articles with contaminating odor should not be loaded with other lading susceptible to contamination by these articles.

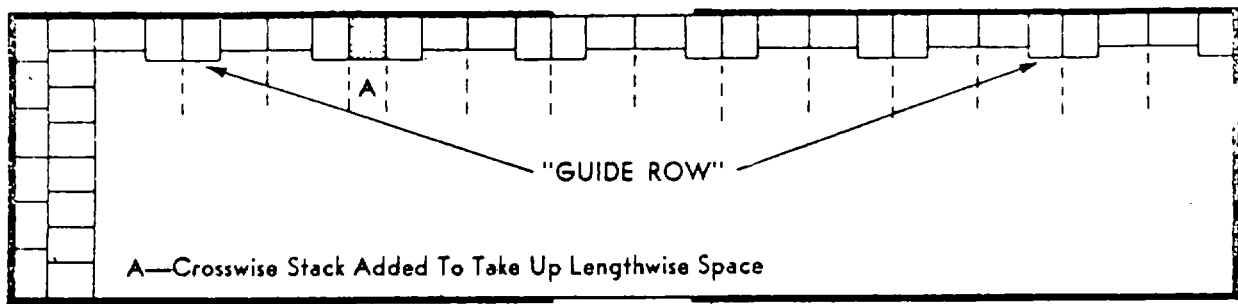
(h) Lading should be loaded in such a manner so as to minimize the need for climbing over freight that is likely to become damaged by weight of stowers.

(i) To be able to block and brace properly, each loading terminal must have sufficient and suitable lumber, plywood sheets, strapping, and fiberboard sheets.

(j) The use of bulkheads to divide the lading into three sections is the ideal method for securing mixed freight.

(k) Before car is closed, the lading must be leveled off or braced.

(l) The loading supervisor should insure proper marking of freight for designated car; freight is loaded into correct car; lading count is accurate and markings on freight are proper and legible; proper stowing and handling of freight from dock to cars; freight is adequately



3

Figure 61. Guide Row.

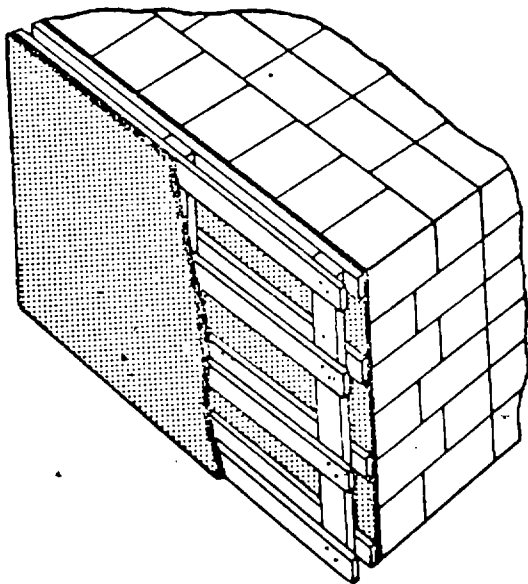


Figure 62. Fiberboard material or bulkheads used to fill vacant space.

packaged; and recoopering is accomplished when necessary.

*b. Machinery.*

(1) Machinery presents special shipping problems, as most units are unique in configuration, size, construction, weight, and weight distribution. For safe transport, most machinery must be properly crated, skid mounted, or otherwise prepared by the shipper, as explained and illustrated in AAR Pamphlet No. 21, Rules Regulating the Preparation and Safe Loading of Machinery in Closed Cars (app A).

(2) Damage to machinery can be prevented by proper preparation of the units for transportation, and by following basic loading and bracing principles; such as-

- (a) Always load units with skids lengthwise of the car.
- (b) Never fasten skid runners to the car floor.

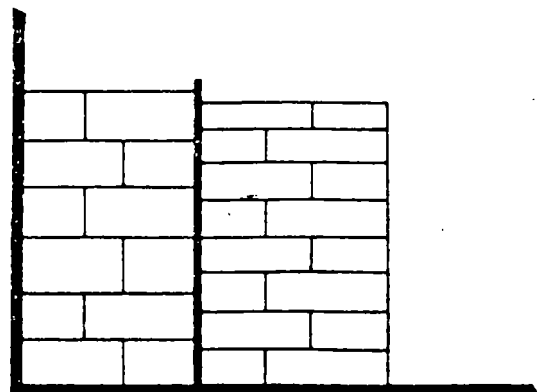


Figure 63. Divider sheets.

(c) Load machines with overhanging projections far enough away from car sides, end walls, and other freight to prevent damage.

(d) Do not load loose parts or other freight adjacent to machines where a shift is liable to cause damage.

(e) When loading heavy machinery, be certain there is proper weight distribution in the car.

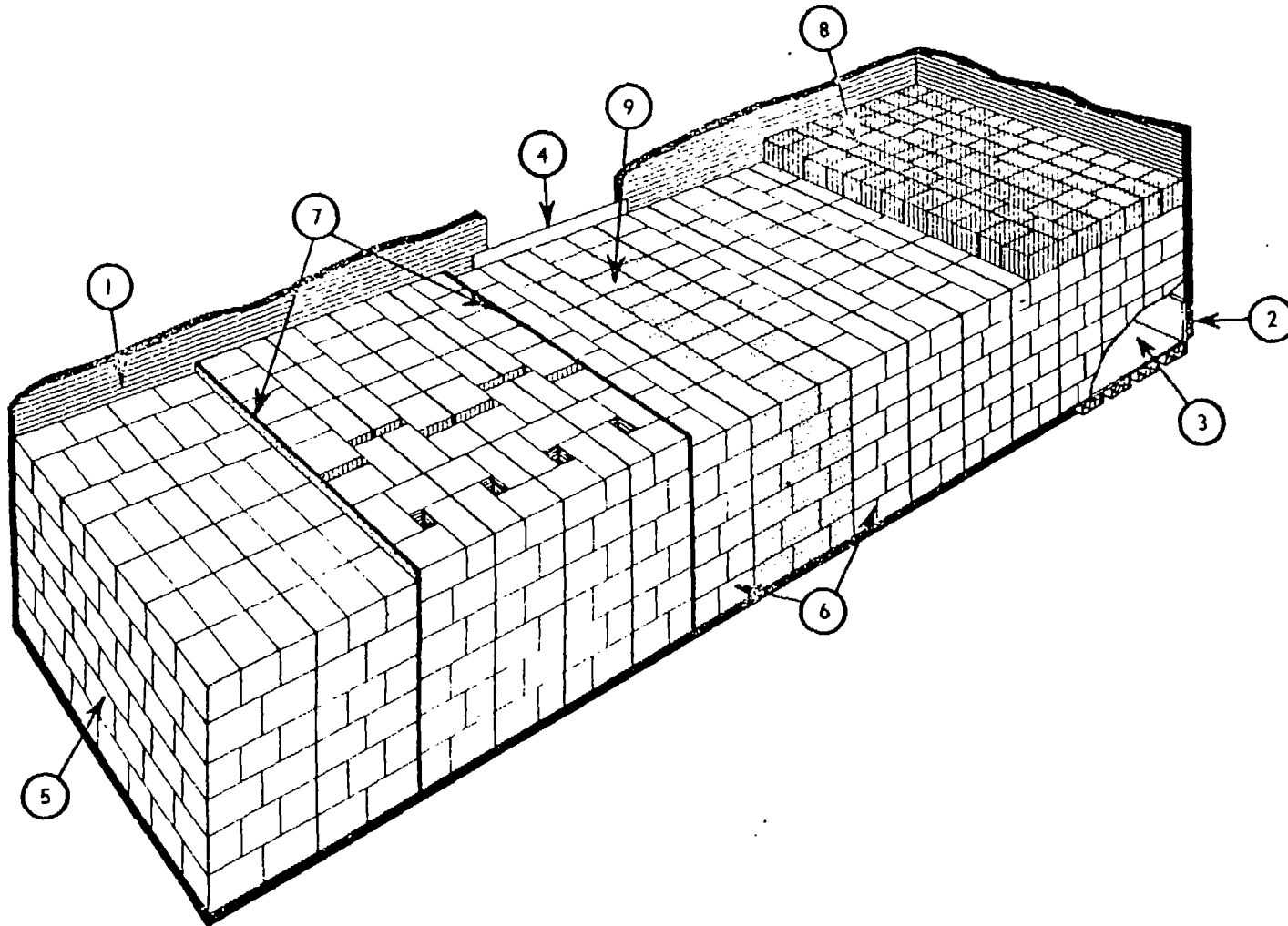
*c. Doorway Protection.*

(1) Doorway protection must be used when railcars are not equipped with plug (flush) doors and freight loaded in the doorway area of the car is liable to contact doorposts and doors.

(2) When lading is only one layer high, one 2-inch x 4-inch piece of lumber nailed to each doorway threshold will usually restrain the load satisfactorily. When lading is in two or more layers, other methods should be used. Figures 72 and 73 depict three types of doorway protection.

**7. Loading of Hazardous Materials**

All shipments in the United States of hazardous materials, such as explosives, flammables, acids, corrosive liquids, etc., must be packaged, blocked, and braced in accordance with Mr. R. M. Graziano's Tariff No. 27, or reissues thereof, *Hazardous Materials Regulations of the*



- (1) Remove nails and other obstructions from walls and floors.
- (2) Place board across bunker wall opening when necessary.
- (3) Cover entire floor and bunker wall opening with fiberboard.
- (4) Use flush doorway protection.
- (5) Load by the bonded block method.

- (6) Run trial row and arrange containers to take up lengthwise space.
  - (7) Place fiberboard sheets between stacks of different size containers.
  - (8) Float Incomplete Layer
  - (9) Keep load tight.
- NOTE spot flue front and rear line of containers

**Figure 64. Summarizing recommended carloading practices.**

Department of Transportation (app A). In Canada, shipments must be in accordance with CTC No. 5, or reissues thereof, Regulations for the Transportation of Dangerous Commodities by Rail (app A). In some instances, the containers or transport equipment in

which the material is loaded must be certified and placarded. For trailers and containers see Bureau of Explosives Pamphlet 6C, or reissues thereof (app A).

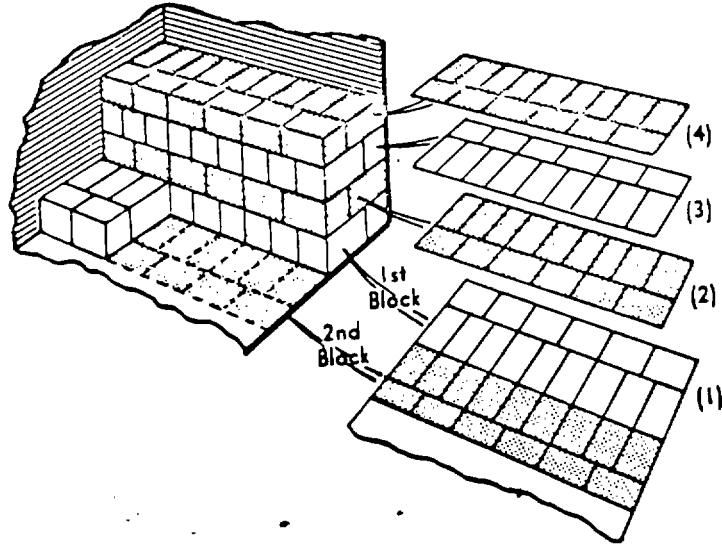


Figure 65. Bonded block pattern A.

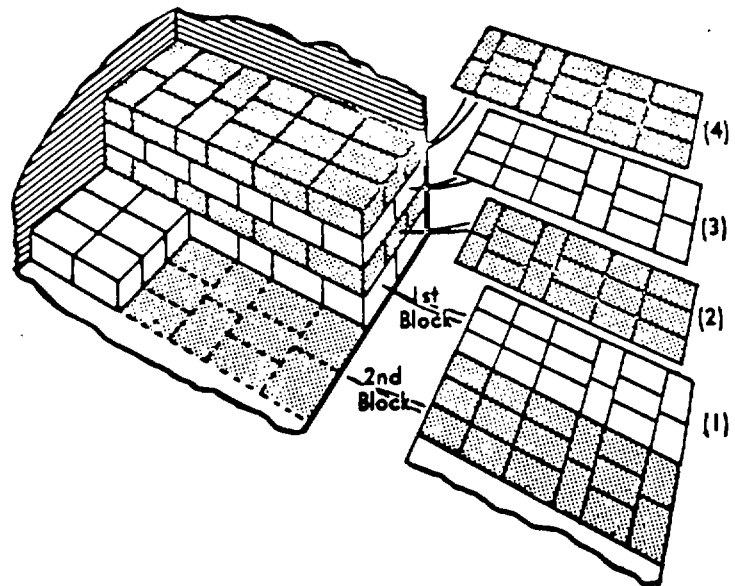


Figure 66. Bonded block pattern B.



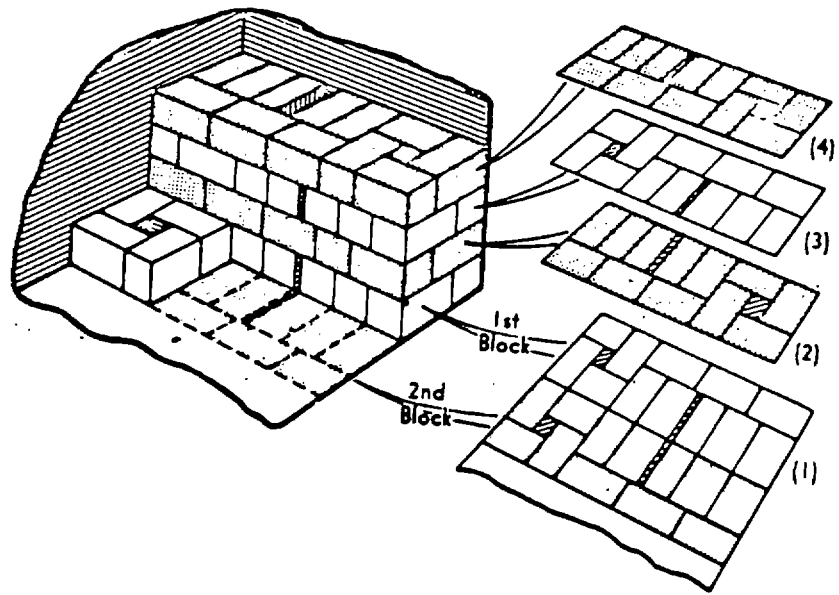
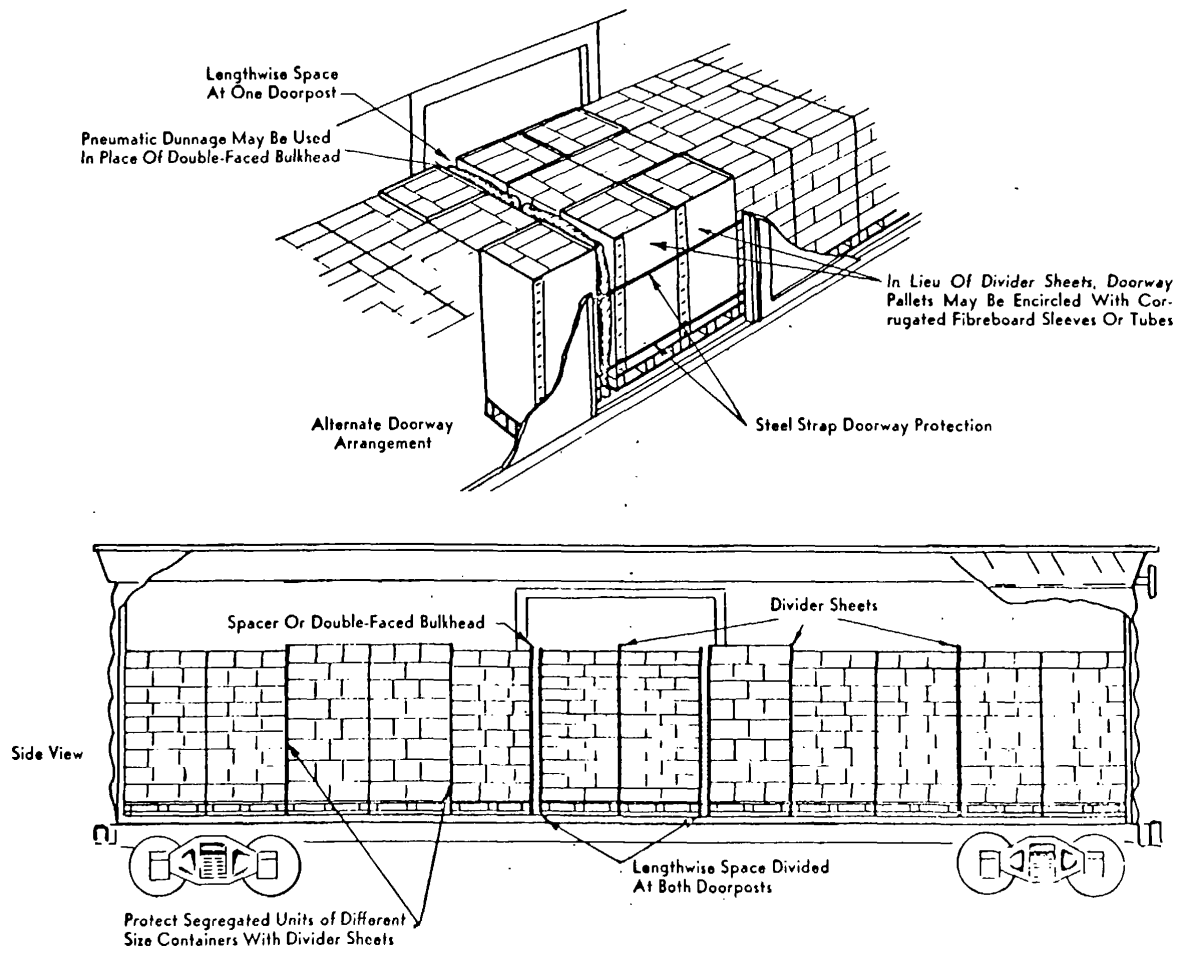
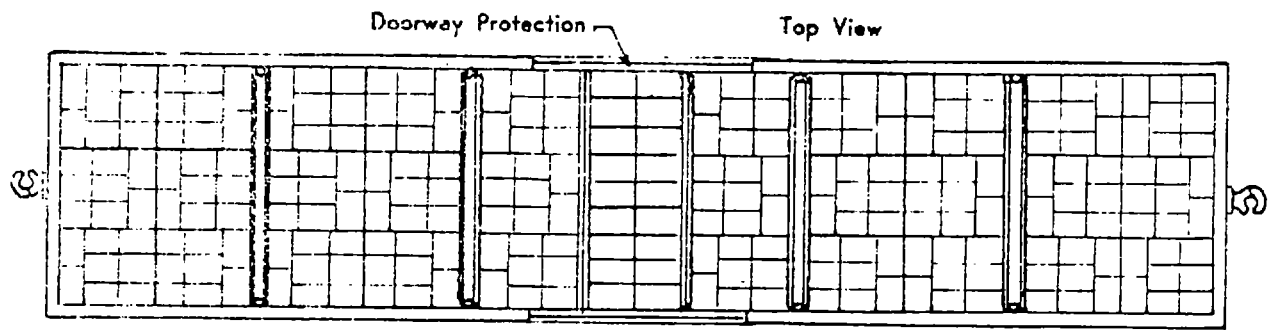


Figure 67. Bonded block pattern C.



**Figure 68. Maximum floor coverage conventional car.**



**GATES FIXED BY SPECIAL LOADER EQUIPMENT**

1. Compartmentizing Load
2. Protect Segregated Units Of Different Size Containers

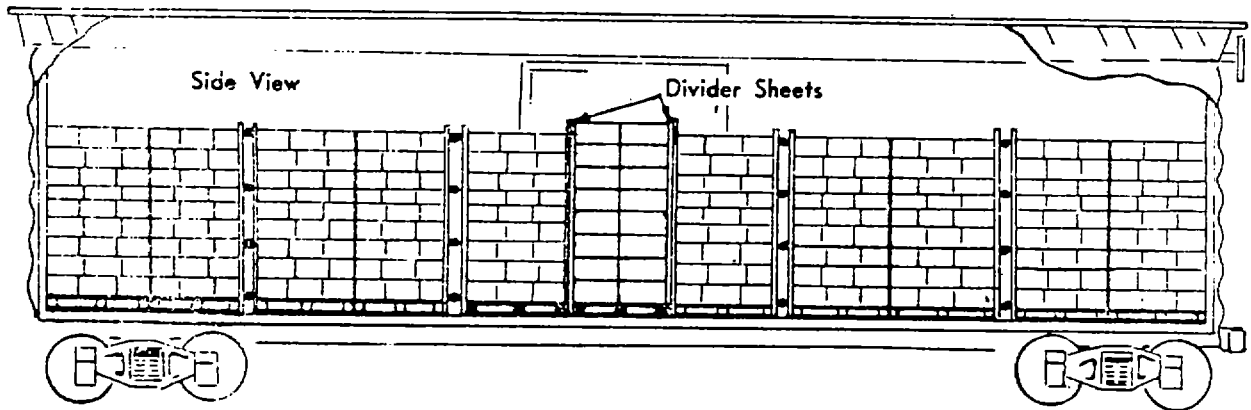
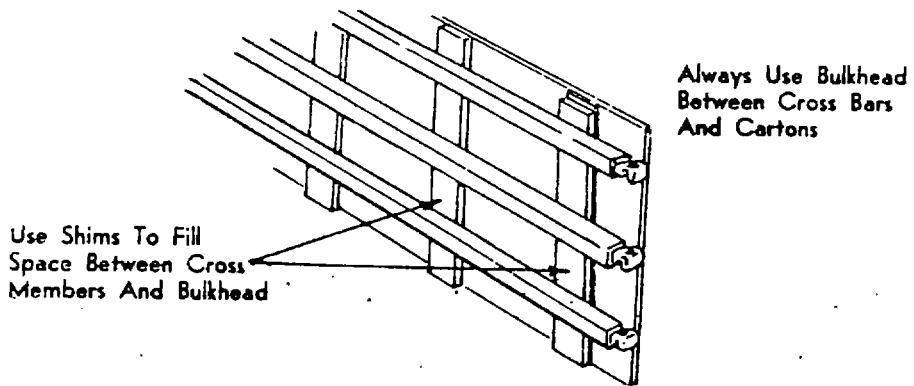
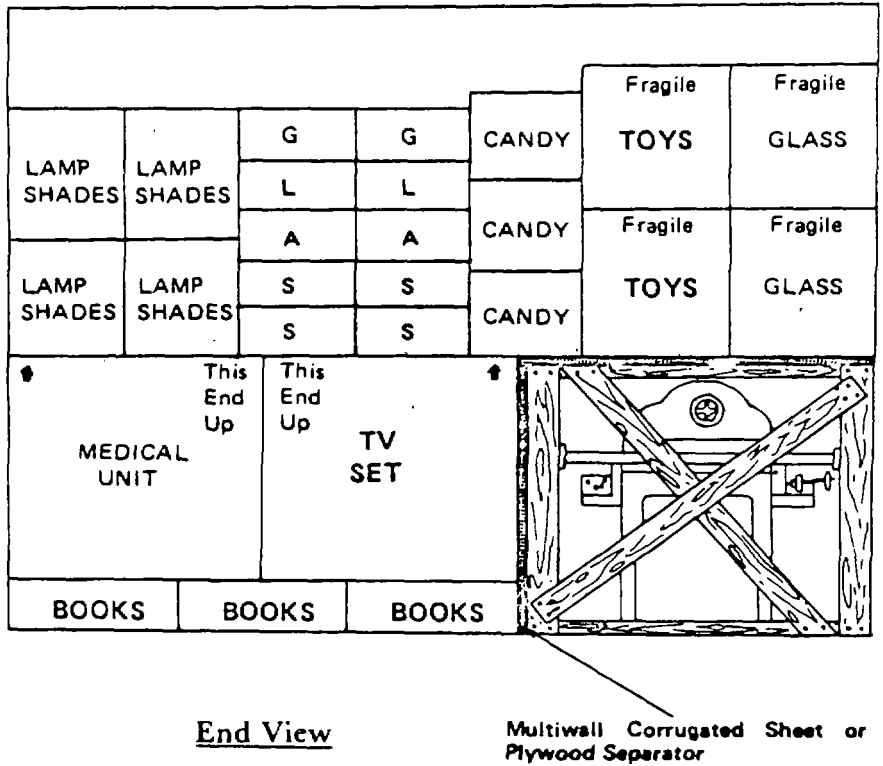


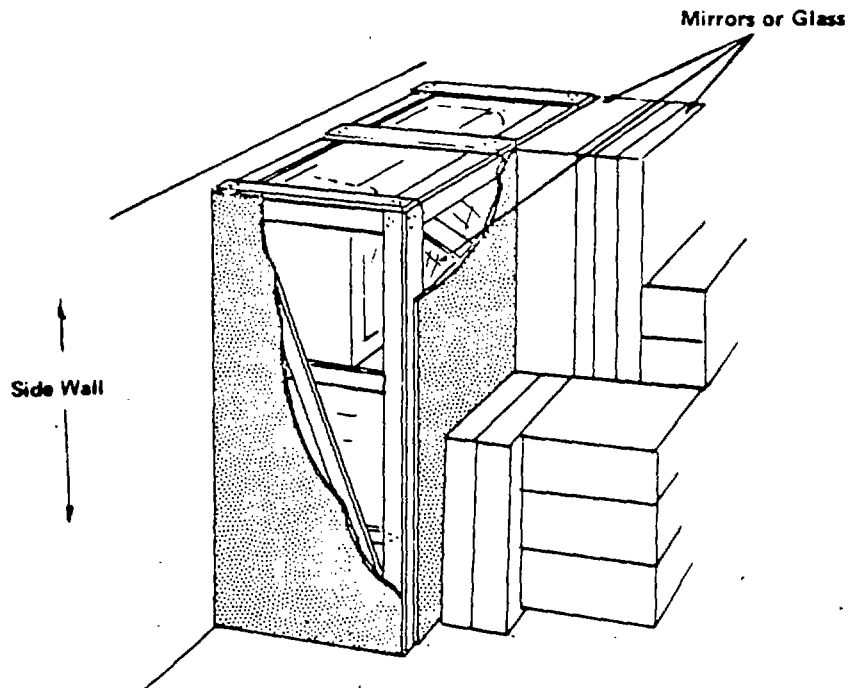
Figure 69. Specially equipped cars.



End View

Multiwall Corrugated Sheet or Plywood Separator

Figure 70. Stowage of different size lading.



Open crate containing large piece. Two layers of corrugated fiberboard (cut away for better perspective) are used to protect against the possibility of small boxes falling down into open crate. This will prevent the contents of the crate from being damaged by falling boxes and will prevent shifting and damage to the boxes.

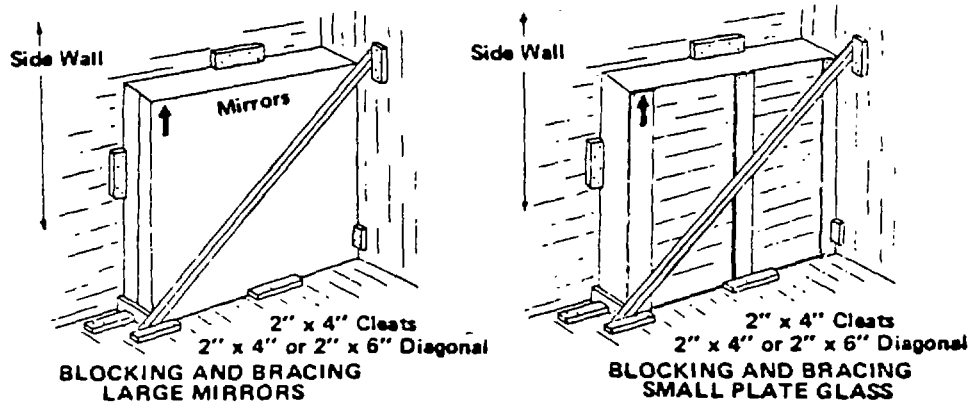


Figure 71. Freight with narrow bases.

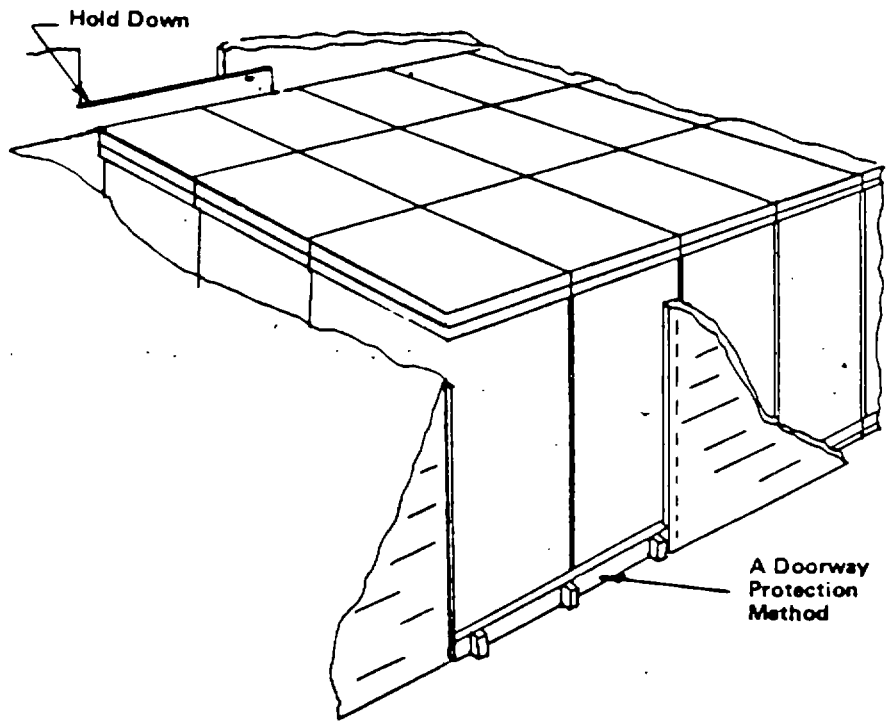
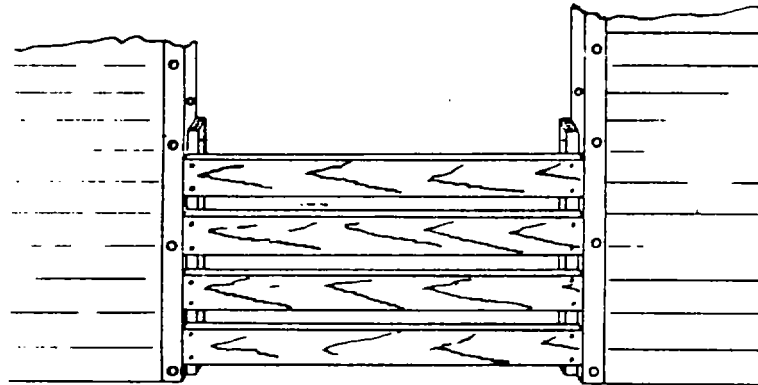


Figure 72. Doorway protection using side blocking.

FOR USE WITH STEEL DOOR POSTS HAVING  
HOLES FOR NAILING



Straps May Be Nailed or Attached To Anchors

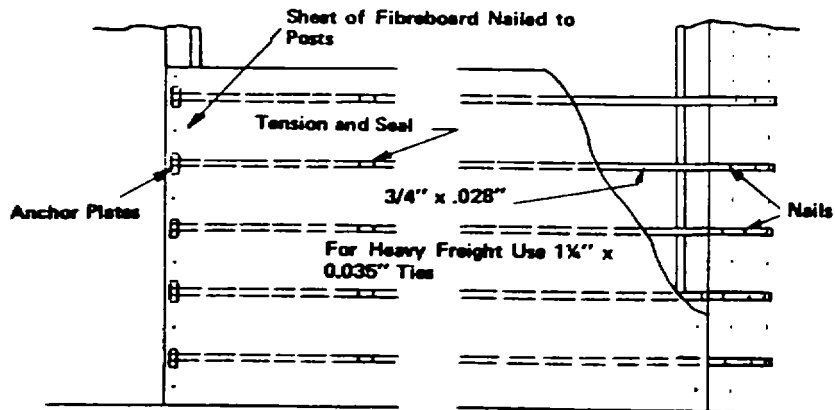


Figure 73. Doorway protection for cars with steel door posts.

## APPENDIX A

### REFERENCES

---

#### 1. Association of American Railroads Loading Pamphlets Governing the Loading of Commodities in Closed Cars

- Pamphlet No.    1. Consolidated Freight (June 1973)  
                    2. Wheeled Vehicles (April 1949)  
                    3. Bags-Commodities In (Nov 1964)  
                    4. Barrels, Drums or Kegs (Nov 1965)  
                    8. Plywood in Closed Cars (June 1971)  
                   13. Cans and Glass in Bottles (June 1973)  
                   14. Rules Regulating the Safe Loading of Freight in Closed Cars and Protection of Equipment (Dec 1963)  
                   16. Furniture Less-Carload (Jan 1963)  
                   18. Cylindrical Steel Containers (Small)-Commodities & Mixed Loads in Larger Steel Drums (Oct 1963)  
                   21. Preparation and Safe Loading of Machinery in Closed Cars (April 1967)  
                   23. Sheet Steel & Tin Plate (Jul 1973)  
                   26. Gypsum, Plasterboard, Lath & Plaster (April 1963)  
                   27. Empty Projectiles, Bombs & Cartridge Cases (Jan 1963)  
                   34. Tank Cars Transporting Non Dangerous Commodities (Nov 1965)  
                   36. Grain & Other Bulk Commodities (Jan 1971)  
                   38. Unsaturated Roofing Felt (Nov 1965)  
                   39. Newsprint (Oct 1970)  
                   40. Vitrified Clay Sewer Pipe (Jan 1963)  
                   41. Dictionary of Standard Terms-Commodities in Closed Cars (Dec 1965)  
                   42. Glass, Rolled & Plate (Nov 1965)  
                    O-T Division Circular  
                   42-D General Rules-Covering Loading of Carload Shipments of Commodities in Closed Cars (June 1967)

#### 2. Other Publications and Source of Procurement

Rail Carriers' Tarriff No. 27, or reissues thereof-Hazardous Materials Regulations of the Department of Transportation Including Specifications for Shipping Containers.

R. M. Graziano, Agent  
American Railroads Building  
1920 L. St. N.W.  
Washington, D.C. 20036

Bureau of Explosives Pamphlet No. 6C  
Association of American Railroads  
2 Penn Plaza  
New York, NY. 10001

Secretary  
Freight Loading and Containers Section  
Association of American Railroads  
59 E. Van Buren Street  
Chicago, Illinois 60605



The Official Railway Equipment and Publication Company, Agent  
W. J. Trezise, Issuing Officer  
424 West 33rd Street,  
New York, N.Y. 10001

Canadian Regulation CTC No. 5

D. W. Davis  
Acting Director of Operations  
Railway Transport Commission  
Canadian Transport Committee  
275 Slater Street  
Ottawa, Ontario

## APPENDIX B AAR DESIGNATING LETTERS AND DEFINITIONS

---

### Class X-Boxcar Type

XM-Box. A house car for general service and especially for lading requiring protection from the weather, with or without lading tie anchors, and equipped with side, or side and end doors.

XC-A house car having individual compartments with a multiplicity of side doors and suitable for general commodity lading.

XL-Loader Equipped. A house car similar in design to XM, either fully or partially lined with steel perforated side walls or equipped with interior side rails or stanchions and crossbar members, for securement of certain types of lading and/or permanently attached movable bulkheads. Cars built or rebuilt since 1966 must have a minimum of four side rails.

XP-A house car similar in design to XM but specially equipped for specific commodity and not suitable for miscellaneous commodity lading.

XR-Auto Device Car. A house car similar in design to XM boxcar, either lined or unlined, with side or side and end doors and equipped with loading racks and/or floor tubes with tiedown chains for loading setup automobiles and trucks.

XT-A house car with or without doors and either metal lined or enclosing one or more tanks.

### Class B-Passenger Type

B-Box Express. A boxcar constructed and equipped to render it suitable for passenger train service, having suitable side doors, with or without end doors or windows.

### Class L-Special Car Type

LB-A house car with high sliding doors at center, both sides. Balance of sides, approximately the lower half, provided each side with two or more doors hinged at top to open outward with suitable locks at bottom.

LC-A house car with side doors and roof hatches. May be equipped with end doors.

LRC-A house car heavily insulated, with or without ventilation, with or without hatches, with or without gravity conveyors for loading or unloading. May have cross partitions forming compartments. Designed primarily for the transportation of solid carbon dioxide.

LU-An enclosed car with roof, having a special metal beam of heavy design at top of each side to support a series of retractable overhead side door and their appurtenances, or other types of doors, running substantially the length of car, which beams also support roof details. Car may be equipped with special loading devices or racks for handling various commodities.

**APPENDIX C**  
**DICTIONARY OF STANDARD TERMS FOR USE IN DESCRIBING LOADING AND BRACING METHODS FOR SHIPMENTS OF COMMODITIES IN CLOSED CARS**

---

(The following information is extracted from AAR Pamphlet No. 41)

**EQUIPMENT**

*B end*-The end of car upon which the brake shaft is located shall be known as B end (fig 74).

*A end*-The end of car opposite to the B end (fig 74).

*R side*-right side. The R side or right side of car is that side of the car on the right of the observer when standing inside of the car and facing the A end (fig 74).

*L side*-left side. The L side or left side of car is that side of the car on the left of the observer when standing inside of the car and facing the A end (fig.74).

*Truck Centers*. The distance from center line to center line of the freight truck bolsters.

*Capacity*-Nominal capacity of the car expressed in round figures (i.e., 120,000 pounds).

*Load Limit*-Maximum total weight of lading and bracing material that may be loaded in a car. Normally stenciled on side wall of each car (i.e., 121,265 pounds).

*Car Braces*-Side Braces and End Braces are steel or wood diagonal members of car superstructure to which inside car lining or sheathing is attached.

*Car Posts*-Corner Posts, Intermediate Posts, and End Posts are vertical steel or wood members of car superstructure to which inside car lining or sheathing is attached.

*DF Type Car*-A specially equipped boxcar having cross bars as a permanent load security devices. The cross bars will be secured to steel rails attached to side walls of car.

*Divider or Compartmentizer Car*-A specially equipped car having gates as permanent load security devices.

*Doorposts*-Steel or wood uprights forming the side frame of the door openings.

*Lining*-A surface (usually wood or metal) fastened to the inside of the car superstructure and/or furring strips.

*Permanent Anchor Plates*-Fixtures attached to the car superstructure on which strap may be secured when using the anchored steel strap loading method.

*Sheathing*-Outside surface of a boxcar.

*Special Equipped Cars*-Boxcars having permanent security devices.

**LOADING OF CONTAINERS**

*Layer*-A course or stratum of the load, parallel to the floor of the car and one container in height.

*Stack*-A pile of containers or articles extending from one side of the car to the other, parallel to the end of the car and one container in length.

*Row*-A pile of containers extending lengthwise of the car, parallel to the sides of the car and one container in width.

*Crosswise*-The arrangement of containers in the car with the ends of the containers facing the sides of the car.

*Guide Row*-A row of containers one layer in height placed along one side of a car for the purpose of determining the number of stacks that can be loaded and the amount of lengthwise space that will remain (fig 75).

*Length of Load*-The space occupied by the containers or articles from end-to-end of car. (It may be obtained by multiplying the average length of a representative container or article by the number of stacks. It does not, however, include the slack in the car nor the space occupied by space fillers.)

*Lengthwise*-The arrangement of containers in the car with the ends of the containers facing the ends of the car.

*Lengthwise Slack*-That portion of lengthwise space not taken up with space fillers. It may be obtained by adding the length of load and the space occupied by space fillers, and subtracting that total from the inside length of the car.

*Lengthwise Space*-The difference between the inside length of the car and the length of load.

**TYPES OF LOAD**

*Anchored Load*-A divided load in which the

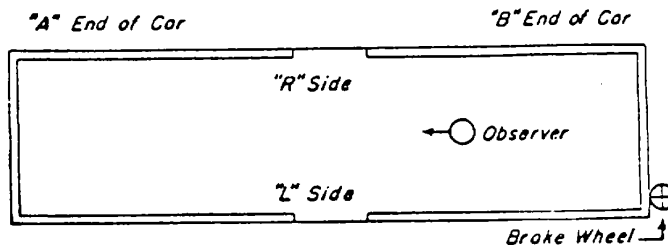


Figure 74. Plan view of car.

Figure 74. Plan view of car.

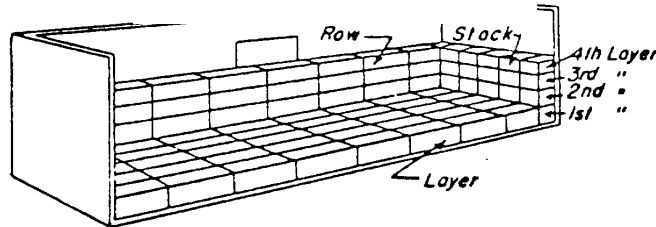


Figure 75. Side view of car.

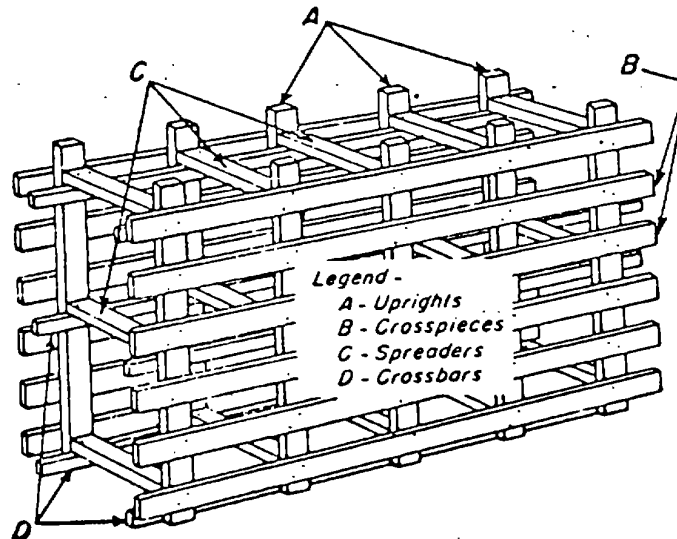


Figure 76. Center gate.

containers are braced away from unfilled space by the use of steel strapping secured to the car.

**Bonded Block Method of Loading**-A method of loading providing for the stowing of containers in a series of blocks, each block being bonded together both lengthwise and crosswise of the car.

**Controlled Floating Load**-A method using controlling plates, anti-skid plates, lag screws, or other retarding devices to hold the lading in I position but which permits a restricted lengthwise movement of the floating load.

**Crosswise Load**-A load in which the containers are arranged crosswise of the car.

**Divided Load**-Containers or commodities are loaded in each end of car having unfilled lengthwise space in doorway area.

**Floating Unit Load**-A load in which the lading is consolidated into one or more units by encircling with steel strapping. Space should be provided at each end of the unit to permit movement over car floor.

**Lengthwise Load**-A load in which the containers are arranged lengthwise of the car.

*Mixed Load*-A load consisting of two or more sizes or types of containers or commodities.

*On-End Load*-The arrangement of containers in the car with the ends of the containers towards the floor of the car.

*Palletized Load*-A method of loading palletized units.

*Rigid Braced Load*-A divided load that is held in fixed position by GATES or CROSS BRACING securely fastened to the car structure.

*Stop-Off Cars*-A load, portions of which are consigned to two or more destinations, to complete loading or unloading.

*Through Load*-A load with or without end gates, in which the containers occupy length of car floor including the doorway area.

## BLOCKING AND BRACING

*A Frame*-A prefabricated structure made in the form of an A and running lengthwise of the car for the shipment of marble slabs or other like articles on edge.

*Anchor Plates*-Steel plates slotted to facilitate the threading and wrapping with steel strap and drilled to permit nailing to car posts or floor. Used with anchored steel strap loading method.

*Backup Cleats*-Cleats that are nailed to car floor or walls and applied lengthwise to car to reinforce blocking and bracing pieces.

*Bearing Pieces*-Material placed on car floor, underneath lading, to facilitate loading or unloading, and to distribute weight of lading over floor of car.

*Bilge Protection*-Horizontal pieces of lumber that are nailed to the end walls of the car and to gates; these pieces being located above and below the bilge of a barrel so as to prevent pressure being exerted upon the bilge.

*Center Cleat (K Brace)*--The member against which the end of the arms of K rest where contacting cross car brace.

*Center Gate*-The structure placed between the two parts of a divided load to fill the lengthwise space not occupied by the load in the doorway. May be a floating type or rigidly attached to the car structure (fig 76).

*Chock Blocks*-Concave or mitered blocking pieces used to secure objects in position.

*Collar Bracing*-Wood or metal members used to secure high objects against tipping lengthwise or crosswise in the car and located above the center of gravity of the object.

*Corner Protection*-Material assembled to form an L and placed against edge of face of load to distribute the pressure of steel straps and prevent cutting of lading.

*Crossbrace*-A single member applied crosswise of car against lading to secure it in position.

*Crosspieces*-The horizontal pieces of wood in a center gate, end gate, or other space fillers extending across the width of

the car. They may be placed directly against the load or may hold in position the uprights that are against the load.

*Divisional or Intermediate Gate*-The structure placed within the load to divide the load into individual units or to segregate loads of different types and sizes of containers or commodities.

*Doorway Protection*-Wood or other material or steel straps, or a combination thereof, extending across the door opening to prevent lading falling or rolling out at doorway or coming in contact with door. If the inside face of the doorway protection is even with the inside face of the car wall, it is called flush.

*End Gate*-The structure placed against the end walls of the car to take up lengthwise space in a through load, or to protect the lading in cars with unlined corrugated steel ends.

*Fillers (Between Layers)*-Material, usually boards, placed between layers of commodities in drums or in other containers.

*Floating Gate*-A Space filler to occupy unfilled lengthwise space and not secured to the car structure.

*Floor Blocking*-Lengthwise or crosswise pieces of lumber nailed to the car floor to secure lading in position in the car.

*Floor Diagonal*-A bracing member applied at an angle with the floor to reinforce a crossbrace.

*Guide Rails*-Side bracing nailed to car floor and applied lengthwise of load to prevent cross car movement or maintain alignment of lading.

*Hold-Down Cleats*-Reinforcing pieces nailed to car walls and used to prevent the rise of cross braces or gates.

*K Brace*-Rigid brace made up of a cross brace that bears against the load, held in position at the car walls with pocket cleats and reinforced by two diagonal pieces likewise secured by pocket cleats to the car walls, the assembled parts resembling the letter K. A crosspiece (one-third car width) is nailed to the center of the main cross brace and separates the diagonal pieces.

*Knee Brace*-A reinforcing member for a floor diagonal. Brace extends from center of floor diagonal to the floor. One end of brace is secured to the diagonal and the other end to a floor cleat.

*Partial Layer*-As distinguished from incomplete layer, partial layer extends length of car as complete rows.

*Pneumatic Dunnage*-Fabricated rubber units capable of inflation to serve as a space filler.

*Pocket Cleats*-Three individual pieces of lumber arranged to form a pocket to receive end

of a cross brace, the upper and lower pieces usually being short and the centerpiece being considerably longer to provide for proper nailing to car walls.

*Side Bracing*-Bracing material used to prevent crosswise movement of lading in car.

*Snubbing Devices*-Anti-skid plates, lag screws, or controlling plates used to retard the movement of a controlled floating load.

*Space Fillers*-Those structures or material used to fill lengthwise space in the car not occupied by the load. They are designated according to type as end gates, center gates, divisional gates, intermediate gates, wedges, or pneumatic dunnage.

*Spreaders*-The horizontal pieces of wood in a center gate placed lengthwise of the car to spread and brace the two sections of the center gate. (Spreaders may be designated by layers and rows, the same as containers.) *Steel Strapping*-A general term for material used to unitize or secure loads. Steel straps are high-tension and may be flat, round, or oval.

*T Brace*-A cross brace including a buffer strip that provides a wide contact surface against the load with a heavier piece nailed thereto at right angles in the form of a T.

*Top or Hold-Down Bracing*-Bracing material placed across the top of the load to hold load down against the car floor.

By Order of the Secretary of the Army:

Official:

VERNE L. BOWERS  
*Major General, United States Army*  
*The Adjutant General*

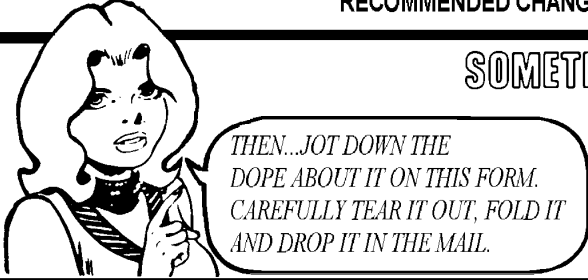
FRED C. WEYAND  
*General, United States Army*  
*Vice Chief of Staff*

Distribution:

To be distributed in accordance with DA Form 1234 (qty rqr block no. 148), requirements for TM 55-series:  
Transportation-Rail Operations.

\*U.S. GOVERNMENT PRINTING OFFICE: 19743-171/5014

RECOMMENDED CHANGES TO EQUIPMENT TECHNICAL PUBLICATIONS

 <p style="font-size: 1.2em; font-weight: bold;">SOMETHING WRONG WITH PUBLICATION</p>		FROM: (PRINT YOUR UNIT'S COMPLETE ADDRESS)		
		DATE SENT		
PUBLICATION NUMBER	PUBLICATION DATE	PUBLICATION TITLE		
<b>BE EXACT PIN-POINT WHERE IT IS</b>				
PAGE NO.	PARA- GRAPH	FIGURE NO.	TABLE NO.	<p style="font-weight: bold;">IN THIS SPACE, TELL WHAT IS WRONG AND WHAT SHOULD BE DONE ABOUT IT.</p>
PRINTED NAME, GRADE OR TITLE AND TELEPHONE NUMBER			SIGN HERE	



## The Metric System and Equivalents

### Linear Measure

1 centimeter = 10 millimeters = .39 inch  
 1 decimeter = 10 centimeters = 3.94 inches  
 1 meter = 10 decimeters = 39.37 inches  
 1 dekameter = 10 meters = 32.8 feet  
 1 hectometer = 10 dekameters = 328.08 feet  
 1 kilometer = 10 hectometers = 3,280.8 feet

### Weights

1 centigram = 10 milligrams = .15 grain  
 1 decigram = 10 centigrams = 1.54 grains  
 1 gram = 10 decigrams = .035 ounce  
 1 decagram = 10 grams = .35 ounce  
 1 hectogram = 10 decagrams = 3.52 ounces  
 1 kilogram = 10 hectograms = 2.2 pounds  
 1 quintal = 100 kilograms = 220.46 pounds  
 1 metric ton = 10 quintals = 1.1 short tons

### Liquid Measure

1 centiliter = 10 milliliters = .34 fl. ounce  
 1 deciliter = 10 centiliters = 3.38 fl. ounces  
 1 liter = 10 deciliters = 33.81 fl. ounces  
 1 dekaliter = 10 liters = 2.64 gallons  
 1 hectoliter = 10 dekaliters = 26.42 gallons  
 1 kiloliter = 10 hectoliters = 264.18 gallons

### Square Measure

1 sq. centimeter = 100 sq. millimeters = .155 sq. inch  
 1 sq. decimeter = 100 sq. centimeters = 15.5 sq. inches  
 1 sq. meter (centare) = 100 sq. decimeters = 10.76 sq. feet  
 1 sq. dekameter (are) = 100 sq. meters = 1,076.4 sq. feet  
 1 sq. hectometer (hectare) = 100 sq. dekameters = 2.47 acres  
 1 sq. kilometer = 100 sq. hectometers = .386 sq. mile

### Cubic Measure

1 cu. centimeter = 1000 cu. millimeters = .06 cu. inch  
 1 cu. decimeter = 1000 cu. centimeters = 61.02 cu. inches  
 1 cu. meter = 1000 cu. decimeters = 35.31 cu. feet

## Approximate Conversion Factors

<i>To change</i>	<i>To</i>	<i>Multiply by</i>	<i>To change</i>	<i>To</i>	<i>Multiply by</i>
inches	centimeters	2.540	ounce-inches	Newton-meters	.007062
feet	meters	.305	centimeters	inches	.394
yards	meters	.914	meters	feet	3.280
miles	kilometers	1.609	meters	yards	1.094
square inches	square centimeters	6.451	kilometers	miles	.621
square feet	square meters	.093	square centimeters	square inches	.155
square yards	square meters	.836	square meters	square feet	10.764
square miles	square kilometers	2.590	square meters	square yards	1.196
acres	square hectometers	.405	square kilometers	square miles	.386
cubic feet	cubic meters	.028	square hectometers	acres	2.471
cubic yards	cubic meters	.765	cubic meters	cubic feet	35.315
fluid ounces	milliliters	29.573	cubic meters	cubic yards	1.308
pints	liters	.473	milliliters	fluid ounces	.034
quarts	liters	.946	liters	pints	2.113
gallons	liters	3.785	liters	quarts	1.057
ounces	grams	28.349	liters	gallons	.264
pounds	kilograms	.454	grams	ounces	.035
short tons	metric tons	.907	kilograms	pounds	2.205
pound-feet	Newton-meters	1.356	metric tons	short tons	1.102
pound-inches	Newton-meters	.11296			

## Temperature (Exact)

°F	Fahrenheit temperature	5/9 (after subtracting 32)	Celsius temperature	°C
----	---------------------------	-------------------------------	------------------------	----

