

# Radio Communications

In the Digital Age

Volume 1  
HF TECHNOLOGY  
Edition 2

**HARRIS**<sup>®</sup>  
*assuredcommunications*<sup>™</sup>

First Edition: September 1996

Second Edition: October 2005

© Harris Corporation 2005

All rights reserved

Library of Congress Catalog Card Number: 96-94476

Harris Corporation, RF Communications Division

Radio Communications in the Digital Age

Volume One: HF Technology, Edition 2

Printed in USA

© 10/05 R.O. 10K

B1006A

All Harris RF Communications products and systems included herein  
are registered trademarks of the Harris Corporation.

## **TABLE OF CONTENTS**

INTRODUCTION .....	1
<b>CHAPTER 1</b>	
PRINCIPLES OF RADIO COMMUNICATIONS .....	6
<b>CHAPTER 2</b>	
THE IONOSPHERE AND HF RADIO PROPAGATION.....	16
<b>CHAPTER 3</b>	
ELEMENTS IN AN HF RADIO .....	24
<b>CHAPTER 4</b>	
NOISE AND INTERFERENCE.....	36
<b>CHAPTER 5</b>	
HF MODEMS .....	40
<b>CHAPTER 6</b>	
AUTOMATIC LINK ESTABLISHMENT (ALE) TECHNOLOGY .....	48

<b>CHAPTER 7</b>	
DIGITAL VOICE .....	55
<b>CHAPTER 8</b>	
DATA SYSTEMS .....	59
<b>CHAPTER 9</b>	
SECURING COMMUNICATIONS .....	71
<b>CHAPTER 10</b>	
FUTURE DIRECTIONS .....	77
<b>APPENDIX A</b>	
STANDARDS .....	79
<b>APPENDIX B</b>	
GLOSSARY .....	81
FURTHER READING .....	93

# INTRODUCTION

Military organizations have used HF radios for both strategic and tactical communications for more than 80 years; however, with the advent of satellites, HF had been de-emphasized and fell into disuse. As a result of that, many present-day communicators don't have an understanding of what modern HF communication capabilities are.

This document is a layman's tutorial on HF radio communications. It presents reasons why HF radio should be considered as a communications means and the unique advantages and versatility of the medium. It explains how HF, even at the low power levels of packsets or vehicular radios, can be used for:

**Line-of-Sight (LOS):** Range, typically less than 30 km, is limited by terrain obstructions and/or earth curvature.

- + Range is also a function of operating frequency, power level, and antenna height.
- + Offers possibility of high data rate transmission.
- + Restricting range reduces adjacent area interference and eases frequency reuse requirements.

**Ground (surface) Wave:** Useful range is up to 50 km on land, 300 or more km over the sea.

- + Range depends on operating frequency and terrain obstructions.
- + Requires vertically polarized antennas.
- + Historically used for voice communications. Data rates are generally high, but may have some limitations depending on waveform used.

Note: HF often provides "extended LOS" coverage compared to VHF communications and is often used when operators require greater distance than VHF radios can provide.

**Beyond Line-of-Sight (BLOS):** Range to about 400 km using Near Vertical Incidence Skywave (NVIS).

- + Can be used where satellite communication is not available.
- + Terrain obstruction not a limiting factor, HF can communicate over mountains etc.
- + Requires horizontally polarized antennas.
- + Frequency range generally restricted to < 10 MHz.
- + Voice or low/medium rate data, data rate depends on waveform.
- + Operating frequency often dependent on ionospheric conditions and Solar Cycles.
- + Automatic Link Establishment (ALE) helps solve the operating frequency selection problem.

**Long Range Communications:** Communications to ranges to 4000 km and beyond.

- + Range depends on antenna, power level, atmospheric conditions.
- + Operating frequency selection is more difficult — ALE is really useful here.
- + Often requires directional antennas.

**By judicious choice of operating frequency and antenna, the same HF radio can provide communications ranging from short range to long range communications.**

We've all seen black-and-white wartime film clips of radio operators sending Morse code using bulky radio equipment. After World War II, the communications industry turned its attention to other technologies, leading to a period of slow growth in High-Frequency (HF) radio communications during the 1960s and 1970s. However, HF, also known as short wave, has undergone an exciting revival propelled by an infusion of new technology.

## GENESIS

Modern radio technology had its birth with the publication of James Clerk Maxwell's Treatise on Electricity and Magnetism in 1873, setting forth the basic theory of electromagnetic wave propagation.

But the first radio waves were actually detected 15 years later. In 1888, Heinrich Rudolph Hertz (the scientist for whom the unit of frequency is named) demonstrated that disturbances generated by a spark coil showed the characteristics of Maxwell's radio waves. His work inspired Guglielmo Marconi's early experiments with wireless telegraphy using Morse code. By 1896, Marconi had communicated messages over distances of a few kilometers.

It was thought at the time that radio waves in the atmosphere traveled in straight lines and that they; therefore, would not be useful for over-the-horizon communication. That opinion did not discourage Marconi, however, who became the first to demonstrate the transmission of radio waves over long distances. In 1901 in Newfoundland, Canada, he detected a telegraphic signal transmitted from Cornwall, England, 3,000 kilometers away. For an antenna, he used a wire 120 meters long, held aloft by a simple kite.

Marconi's success stimulated an intensive effort to explain and exploit his discovery. The question of how radio waves could be received around the surface of the earth was eventually answered by Edward Appleton. It was this British physicist who discovered that a blanket of electrically charged, or "ionized," particles in the earth's atmosphere (the ionosphere) were capable of reflecting radio waves. By the 1920s, scientists had applied this theory and developed ways to measure and predict the refractive properties of the ionosphere.

## **GROWTH**

In time, the characteristics of HF radio propagation became better understood. Operators learned, for example, that usable frequencies varied considerably with time of day and season. HF technology developed quickly.

By World War II, HF radio was the primary means of long-haul communications for military commanders because it provided communications with land, sea, and air forces.

In the hands of a skilled operator armed with years of experience and an understanding of the propagating effects of the ionosphere, HF

radio was routinely providing reliable, effective links over many thousands of miles. Today, HF radio also plays an important role in allowing emerging nations to establish a national communications system quickly and inexpensively.

## **HIATUS**

The advent of long-range communications by satellite in the 1960s initiated a period of declining interest in HF radio. Satellites carried more channels and could handle data transmission at higher speeds. Additionally, satellite links seemed to eliminate the need for highly trained operators. As long-range communications traffic migrated to satellites, HF was often relegated to a backup role. The result was user preference for wider bandwidth methods of communication, such as satellites, resulting in declining proficiency in HF as the number of experienced radio operators decreased.

It became clear over time, however, that satellites (for all their advantages) had significant limitations. Military users became increasingly concerned about the vulnerability of satellites to jamming and physical damage, and questioned the wisdom of depending exclusively on them. Moreover, satellites and their supporting infrastructure are expensive to build and maintain, and there are a limited number of channels available.

## **REVIVAL**

In the last decade, we've seen major resurgence in HF radio. Research and development activity has intensified, and a new generation of automated HF equipment has appeared. These systems provide dramatic improvements in automation, reliability, and throughput. Today's Automatic Link Establishment (ALE)-based HF radios are as easy to use as wireless telephones.

Nonetheless, the perception that HF radio is an inherently difficult-to-use medium continues to linger. This perception continues because some communicators remember how HF used to be.



As your interest in this book shows, HF is again being recognized as a robust and highly competitive medium for long-haul communications, offering countless capabilities. In this introduction to HF radio communications, we present information that will help you understand modern HF radio technology. We'll cover the principles of HF radio, talk about specific applications, and then, consider the future of HF radio communication.

## CHAPTER 1

# PRINCIPLES OF RADIO COMMUNICATIONS

An understanding of radio communications begins with the comprehension of basic electromagnetic radiation.

Radio waves belong to the electromagnetic radiation family, which includes x-ray, ultraviolet, and visible light. Much like the gentle waves that form when a stone is tossed into a still lake, radio signals radiate outward, or propagate, from a transmitting antenna. However, unlike water waves, radio waves propagate at the speed of light.

We characterize a radio wave in terms of its amplitude, frequency, and wavelength (**Figure 1-1**).

Radio wave amplitude, or strength, can be visualized as its height being the distance between its peak and its lowest point. Amplitude, which is measured in volts, is usually expressed in terms of an average value called root-mean-square, or RMS.

The frequency of a radio wave is the number of repetitions or cycles it completes in a given period of time. Frequency is measured in Hertz (Hz); one Hertz equals one cycle per second. Thousands of Hertz are expressed as kilohertz (kHz), and millions of Hertz as megahertz (MHz). You would typically see a frequency of 2,345,000 Hertz, for example, written as 2,345 kHz or 2.345 MHz.

Radio wavelength is the distance between crests of a wave. The product of wavelength and frequency is a constant that is equal to the speed of propagation. Thus, as the frequency increases, wavelength decreases, and vice versa. Radio waves propagate at the speed of light (300 million meters per second). To determine the wavelength in meters for any frequency, divide 300 by the frequency in megahertz. So, the wavelength of a 10 MHz wave is 30 meters, determined by dividing 300 by 10.

**FIGURE 1-1 | Radio Wave Properties**

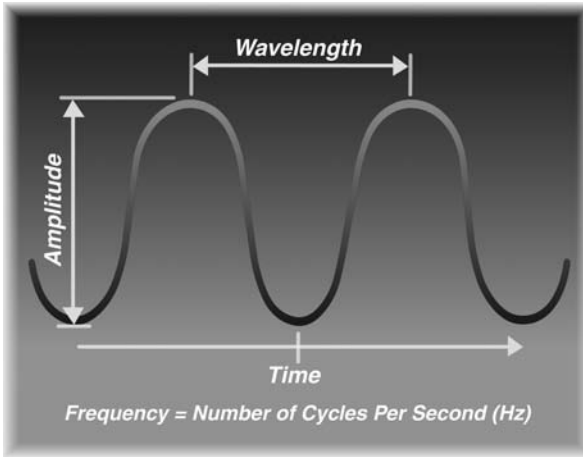

**FIGURE 1-2 | Radio Frequency Spectrum**

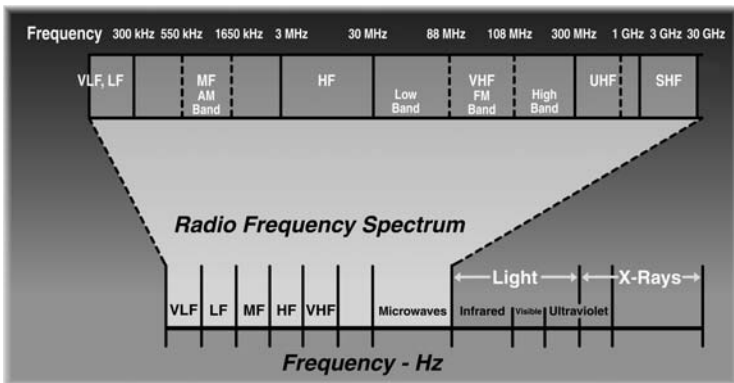

## THE RADIO FREQUENCY SPECTRUM

In the radio frequency spectrum (**Figure 1-2**), the usable frequency range for radio waves extends from about 20 kHz (just above sound waves) to above 30,000 MHz. A wavelength at 20 kHz is 15 kilometers long. At 30,000 MHz, the wavelength is only 1 centimeter.

The HF band is defined as the frequency range of 3 to 30 MHz. In practice, most HF radios use the spectrum from 1.6 to 30 MHz. Most long-haul communications in this band take place between 4 and 18 MHz. Higher frequencies (18 to 30 MHz) may also be available from time to time, depending on ionospheric conditions and the time of day. (See **Chapter 2**.)

In the early days of radio, HF frequencies were called short wave because their wavelengths (10 to 100 meters) were shorter than those of commercial broadcast stations. The term is still applied to long-distance radio communications.

## FREQUENCY ALLOCATIONS AND MODULATION

Within the HF spectrum, groups of frequencies are allocated to specific radio services — aviation, maritime, military, government, broadcast, or amateur (**Figure 1-3**). Frequencies are further regulated according to transmission type: emergency, broadcast, voice, Morse code, facsimile, and data. Frequency allocations are governed by international treaty and national licensing authorities. The allocation of a frequency is just the beginning of radio communications. By itself, a radio wave conveys no information. It's simply a rhythmic stream of continuous waves (CW).

When we modulate radio waves to carry information, we refer to them as carriers. To convey information, a carrier must be varied so that its properties — its amplitude, frequency, or phase (the measurement of a complete wave cycle) — are changed, or modulated, by the information signal.

The simplest method of modulating a carrier is by turning it on and off by means of a telegraph key. On-off keying (using Morse code) was the only method of conveying wireless messages in the early days of radio.

**FIGURE 1-3 | Principles: Frequency Allocations**

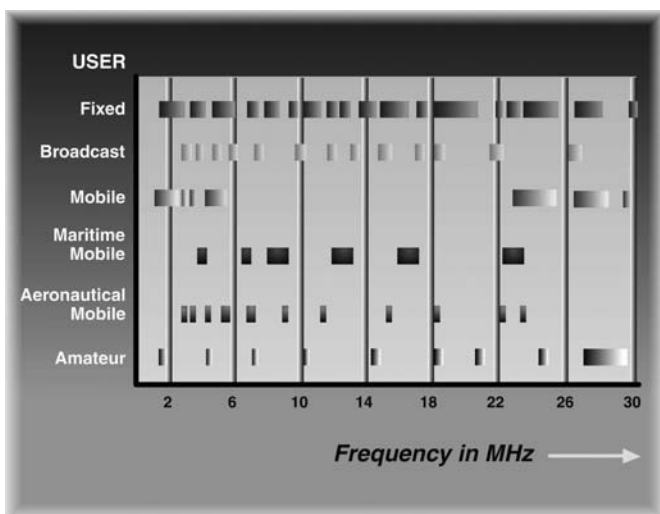

**FIGURE 1-4 | Amplitude Modulation**

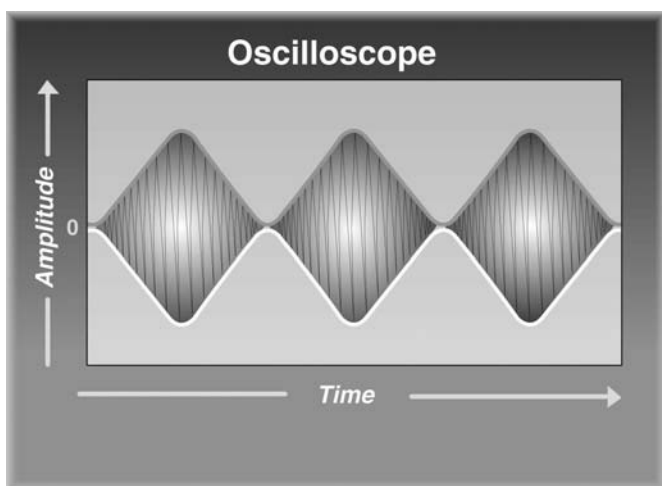

Today's common methods for radio communications include amplitude modulation (AM), which varies the strength of the carrier in direct proportion to changes in the intensity of a source such as the human voice (**Figure 1-4**). In other words, information is contained in amplitude variations.

The AM process creates a carrier and a pair of duplicate sidebands — nearby frequencies above and below the carrier (**Figure 1-5**). AM is a relatively inefficient form of modulation, since the carrier must be continually generated. The majority of the power in an AM signal is consumed by the carrier that carries no information, with the rest going to the information-carrying sidebands.

In a more efficient technique, single sideband (SSB), the carrier and one of the sidebands are suppressed (**Figure 1-6**). Only the remaining sideband — upper (USB) or lower (LSB) — is transmitted. An SSB signal needs only half the bandwidth of an AM signal and is produced only when a modulating signal is present. Thus, SSB systems are more efficient both in the use of the spectrum, which must accommodate many users, and of transmitter power. All the transmitted power goes into the information-carrying sideband.

One variation on this scheme, often used by military and commercial communicators, is amplitude modulation equivalent (AME), in which a carrier at a reduced level is transmitted with the sideband. AME lets one use a relatively simple receiver to detect the signal. Another important variation is independent sideband (ISB), in which both an upper and lower sideband, each capable of carrying different information, are transmitted. This way, for example, one sideband can carry a data signal and the other can carry a voice signal (**Figure 1-7**).

Frequency modulation (FM) is a technique in which the carrier's frequency is varied to convey the signal. For a variety of technical reasons, conventional FM generally produces a cleaner signal than AM, but uses much more bandwidth than AM. Narrowband FM, which is sometimes used in HF radio, uses less bandwidth, but only at the cost of signal quality.

**FIGURE 1-5** | Amplitude Modulation Sidebands

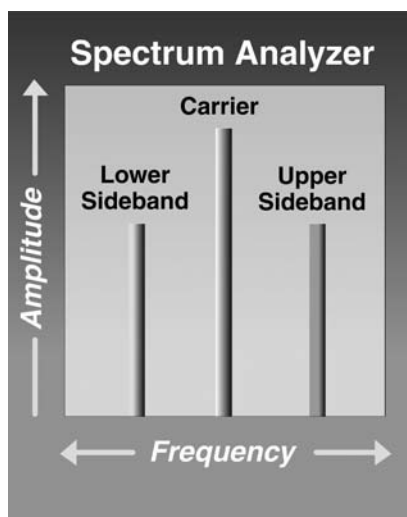

**FIGURE 1-6** | Modulation, Single Sideband

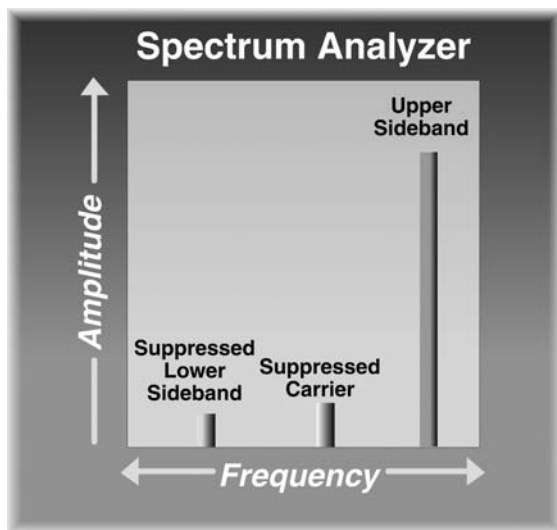

**FIGURE 1-7** | Modulation: Independent Sideband

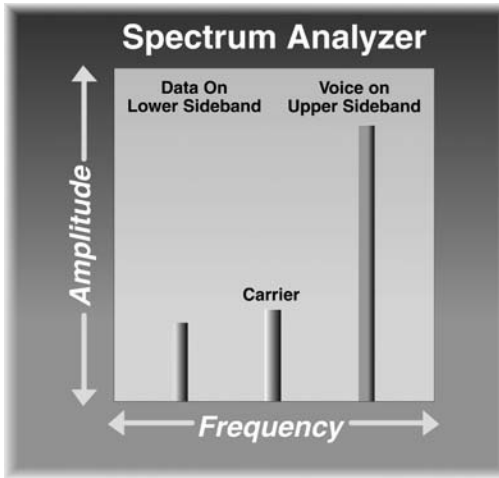

**FIGURE 1-8** | Propagation Paths

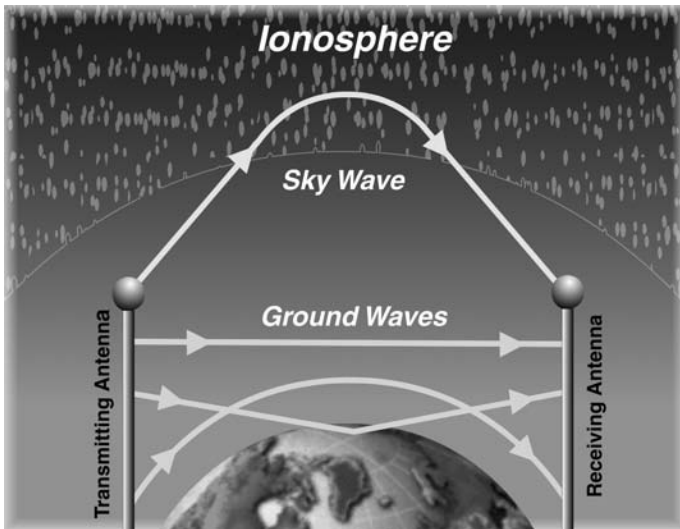



Other schemes support the transmission of data over HF channels, including shifting the frequency or phase of the signal. We will cover these techniques in **Chapter 5**.

### **Radio Wave Propagation**

Propagation is defined as how radio signals radiate outward from a transmitting source. Radio waves are often believed to travel in a straight line like a stone tossed into a still lake. The true path radio waves take, however, is often more complex.

There are two basic modes of propagation: ground waves and sky waves. As their names imply, ground waves travel along the surface of the earth, while sky waves “bounce” back to earth. **Figure 1-8** shows the different propagation paths for HF radio waves.

Ground waves consist of three components: surface waves, direct waves, and ground-reflected waves. Surface waves travel along the surface of the earth, reaching beyond the horizon. Eventually, surface wave energy is absorbed by the earth. The effective range of surface waves is largely determined by the frequency and conductivity of the surface over which the waves travel. Absorption increases with frequency.

Transmitted radio signals, which use a carrier traveling as a surface wave, are dependent on transmitter power, receiver sensitivity, antenna characteristics, and the type of path traveled. For a given complement of equipment, the range may extend from 200 to 300 km over a conductive, all-sea-water path. Over arid, rocky, non-conductive terrain, however, the range may drop to less than 30 km, even with the same equipment.

Direct waves travel in a straight line, becoming weaker as distance increases. They may be bent, or refracted, by the atmosphere, which extends their useful range slightly beyond the horizon. Transmitting and receiving antennas must be able to “see” each other for communications to take place, so antenna height is critical in determining range. Because of this, direct waves are sometimes known as line-of-sight (LOS) waves.

Ground-reflected waves are the portion of the propagated wave that is reflected from the surface of the earth between the transmitter and receiver.

Sky waves make beyond line-of-sight (BLOS) communications possible. At certain frequencies, radio waves are refracted (or bent), returning to earth hundreds or thousands of miles away. Depending on frequency, time of day, and atmospheric conditions, a signal can bounce several times before reaching a receiver.

Using sky waves can be tricky, since the ionosphere is constantly changing. In the next chapter, we'll discuss sky waves in greater detail.

## **SUMMARY**

Radio signals propagate from a transmitting antenna as waves through space at the speed of light.

Radio frequency is expressed in terms of hertz (cycles per second), kilohertz (thousands of Hertz), or megahertz (millions of Hertz).

Frequency determines the length of a radio wave; lower frequencies have longer wavelengths and higher frequencies have shorter wavelengths.

Long-range radio communications take place in the high-frequency (HF) range of 1.6 to 30 MHz. Different portions of this band are allocated to specific radio services under international agreement.

Modulation is the process whereby the phase, amplitude, or frequency of a carrier signal is modified to convey intelligence.

HF radio waves can propagate as sky waves, which are refracted from the earth's ionosphere, permitting communications over long distances.

## CHAPTER 2

# THE IONOSPHERE AND HF RADIO PROPAGATION

To understand sky wave propagation, you need to consider the effects of the ionosphere and solar activity on HF radio propagation. You must also be familiar with the techniques used to predict propagation and select the best frequencies for a particular link at a given time. Let's start with some definitions.

### THE IONOSPHERE, NATURE'S SATELLITE

The ionosphere is a region of electrically charged particles or gases in the earth's atmosphere, extending from approximately 50 to 600 km above the earth's surface. Ionization, the process in which electrons are stripped from atoms and produces electrically charged particles, results from solar radiation. When the ionosphere becomes heavily ionized, the gases may even glow and be visible. This phenomenon is known as Northern and Southern Lights.

Why is the ionosphere important in HF radio? Well, this blanket of gases is like nature's satellite, making HF BLOS radio communications possible. When radio waves strike these ionized layers, depending on frequency, some are completely absorbed, others are refracted so that they return to the earth, and still others pass through the ionosphere into outer space. Absorption tends to be greater at lower frequencies, and increases as the degree of ionization increases.

The angle at which sky waves enter the ionosphere is known as the incident angle (**Figure 2-1**). This is determined by wavelength and the type of transmitting antenna. Like a billiard ball bouncing off a rail, a radio wave reflects from the ionosphere at the same angle it hits it. Thus, the incident angle is an important factor in determining communications range. If you need to reach a station that is relatively far from you, you would want the incident angle to be relatively large. To communicate with a nearby station, the incident angle should be relatively small.

**FIGURE 2-1** | The Ionosphere: Incident Angle

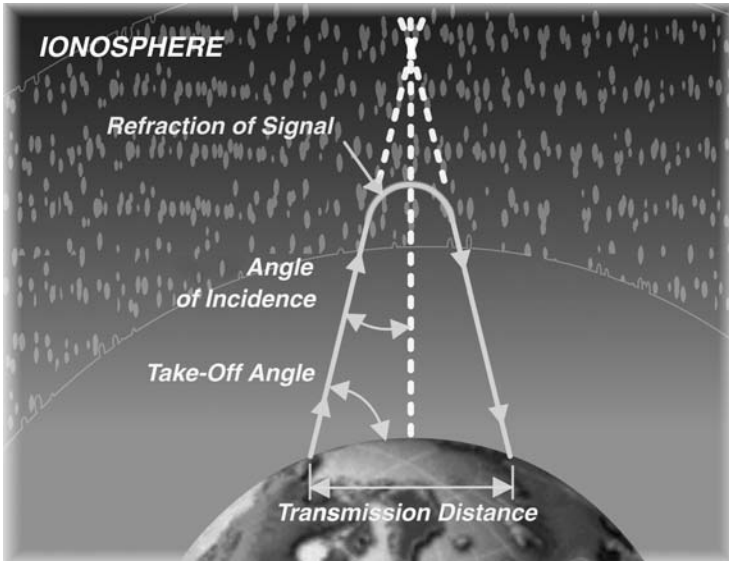

**FIGURE 2-2** | The Ionosphere: Layers

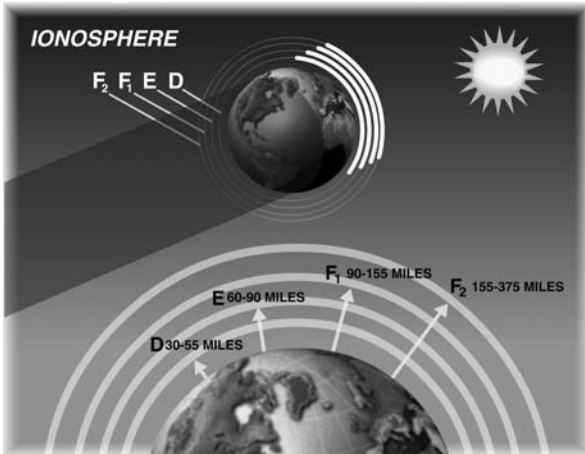

The incident angle of a radio wave is critical because if it is too nearly vertical, it will pass through the ionosphere without being refracted back to earth. If the angle is too great, the waves will be absorbed by the lower layers before reaching the more densely ionized upper layers. So, incident angle must be sufficient for bringing the radio wave back to earth, yet not so great that it will lead to absorption.

## LAYERS OF THE IONOSPHERE

Within the ionosphere, there are four layers of varying ionization (**Figure 2-2**). Since ionization is caused by solar radiation, the higher layers of the ionosphere tend to be more highly ionized, while the lower layers, protected by the outer layers, experience less ionization. Of these layers, the first, discovered in the early 1920s by Appleton, was designated E for electric waves. Later, D and F were discovered and noted by these letters. Additional ionospheric phenomena were discovered through the 1930s and 1940s, such as sporadic E and aurora.

In the ionosphere, the D layer is the lowest region affecting HF radio waves. Ionized during the day, the D layer reaches maximum ionization when the sun is at its zenith and dissipates quickly toward sunset.

The E layer reaches maximum ionization at noon. It begins dissipating toward sunset and reaches minimum activity at midnight. Irregular cloud-like formations of ionized gases occasionally occur in the E layer. These regions, known as sporadic E, can support propagation of sky waves at the upper end of the HF band and beyond.

The most heavily ionized region of the ionosphere, and therefore the most important for long-haul communications, is the F layer. At this altitude, the air is thin enough that the ions and electrons recombine very slowly, so the layer retains its ionized properties even after sunset.

In the daytime, the F layer consists of two distinct layers, F1 and F2. The F1 layer, which exists only in the daytime and is negligible in winter, is not important to HF communications. The F2 layer reaches maximum ionization at noon and remains charged at night, gradually decreasing to a minimum just before sunrise.

During the day, sky wave reflection from the F2 layer requires wavelengths short enough to penetrate the ionized D and E layers, but not so short as to pass through the F layer. Generally, frequencies from 10 to 20 MHz will accomplish this, but the same frequencies used at night would penetrate the F layer and pass into outer space. The most effective frequencies for long-haul nighttime communications are normally between 3 and 8 MHz.

### FACTORS AFFECTING ATMOSPHERIC IONIZATION

The intensity of solar radiation, and therefore ionization, varies periodically. Hence, we can predict solar radiation intensity based on time of day and the season, and make adjustments in equipment to limit or optimize ionization effects.

Ionization is higher during spring and summer because the hours of daylight are longer. Sky waves are absorbed or weakened as they pass through the highly charged D and E layers, reducing, in effect, the communication range of most HF bands.

Because there are fewer hours of daylight during autumn and winter, less radiation reaches the D and E layers. Lower frequencies pass easily through these weakly ionized layers. Therefore, signals arriving at the F layer are stronger and are reflected over greater distances.

Another longer term periodic variation results from the 11-year sunspot cycle (**Figure 2-3**). Sunspots generate bursts of radiation that cause higher levels of ionization. The more sunspots, the greater the ionization. During periods of low sunspot activity, frequencies above 20 MHz tend to be unusable because the E and F layers are too weakly ionized to reflect signals back to earth. At the peak of the sunspot cycle, however, it is not unusual to have worldwide propagation on frequencies above 30 MHz.

In addition to these regular variations, there is a class of unpredictable phenomena known as sudden ionospheric disturbances (SID), which can affect HF communications as well. SIDs are random events due to solar flares that can disrupt sky wave communication for hours or days at a time. Solar flares produce intense ionization of the D layer, causing

**FIGURE 2-3 | Sunspot Cycle: Ionization Factors**

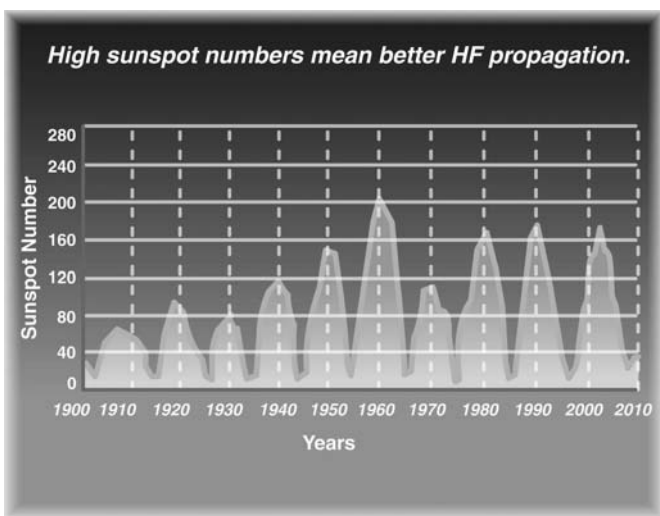

**FIGURE 2-4 | The Ionosphere: FOT**

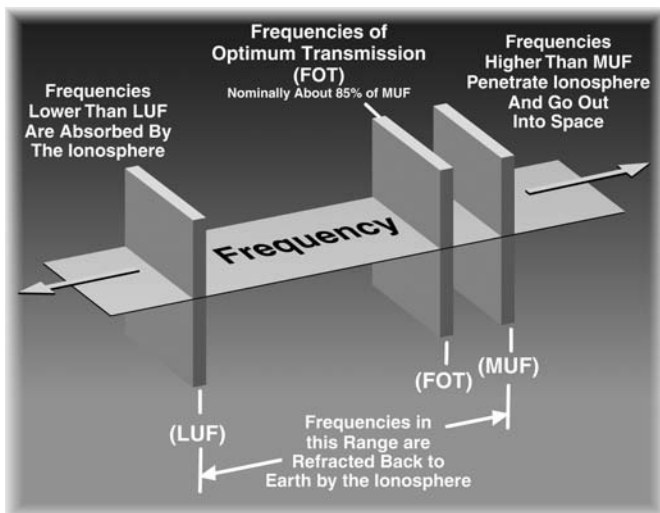



it to absorb most HF signals on the side of the earth facing the sun. Magnetic storms often follow the eruption of solar flares within 20 to 40 hours. Charged particles from the storms have a scattering effect on the F layer, temporarily neutralizing its reflective properties.

## FREQUENCY AND PATH OPTIMIZATION

Because ionospheric conditions affect radio wave propagation, communicators must determine the best way to optimize radio frequencies at a particular time. The highest possible frequency that can be used to transmit over a particular path under given ionospheric conditions is called the Maximum Usable Frequency (MUF). Frequencies higher than the MUF penetrate the ionosphere and continue into space. Frequencies lower than the MUF tend to refract back to earth.

As frequency is reduced, the amount of absorption of the signal by the D layer increases. Eventually, the signal is completely absorbed by the ionosphere. The frequency at which this occurs is called the Lowest Usable Frequency (LUF). The “window” of usable frequencies, therefore, lies between the MUF and LUF.

The Frequency of Optimum Transmission (FOT) is typically 85 percent of the MUF. Generally, the FOT is lower at night and higher during the day. These frequencies are illustrated in **Figure 2-4**.

In addition to frequency, the route the radio signal travels must also be considered in optimizing communications. A received signal may be comprised of components arriving via several routes, including one or more sky wave paths and a ground wave path. The arrival times of these components vary because of differences in path length; the range of time differences is called the multipath spread. The effects of multipath spread can be minimized by selecting a frequency as close as possible to the MUF.

## PROPAGATION PREDICTION TECHNIQUES

Since many of the variables affecting propagation follow repetitive cycles and can be predicted, techniques for effectively determining FOT have been developed.

A number of propagation prediction computer programs are available. Two widely used and effective programs are Ionospheric Communications Analysis and Prediction (IONCAP) and Voice of America Coverage Analysis Program (VOACAP), which predict system performance at given times of day as a function of frequency for a given HF path and a specified complement of equipment.

Of course, since computerized prediction methods are based on historic data, they cannot account for present conditions affecting communications, like ionospheric changes caused by random phenomena such as interference and noise (more about these later).

A more immediate automated prediction method involves ionospheric sounding. One system, the Chirpsounder<sup>®</sup>, uses remote stations to transmit test signals (chirps) that sweep through all frequencies from 2 to 30 MHz. The receiver tracks the signal, analyzes its reception on assigned operating frequencies, and displays frequency ranges for optimum propagation.

In addition, modern HF communications systems make use of Link Quality Analysis (LQA) techniques. In these systems, transmitting and receiving stations cooperate to automatically assess the quality of the channels available to them. When the need to communicate arises, the LQA data is used to select the best frequency. We'll take a closer look at this technique in **Chapter 6**.

## SUMMARY

The ionosphere is a region of electrically charged particles or gases in the earth's atmosphere, extending from 50 to 600 km (approximately 30 to 375 miles) above the earth's surface.

There are layers of varying electron density in the ionosphere that absorb, pass, or reflect radio waves, depending on the density of the layer, the angle with which the radio waves strike it, and the frequency of the signal.

Ionization, caused by solar radiation, strips electrons from atoms, producing electrically charged particles.

The density of ionospheric layers varies with the intensity of solar radiation, which changes according to time of day, season, and sunspot cycle.

The angle of radiation is determined by the wavelength of a signal and the type of antenna used.

Radio waves are absorbed as they pass through the ionosphere. The absorption rate increases as frequency decreases.

Communication is best at the frequency of optimum transmission (FOT), typically 85 percent of the maximum usable frequency (MUF).

Sunspots increase and decrease in 11-year cycles. Higher sunspot numbers increase ionization and therefore improve propagation. Lower sunspot numbers cause less ionization.

Solar flares cause sudden ionospheric disturbances (SIDs), which can disrupt HF communications for short periods of time.

Propagation prediction techniques, such as IONCAP and VOACAP, predict the MUF, LUF, and FOT for a given transmission path and time of day. Other methods include ionospheric sounding and Link Quality Analysis (LQA).

## CHAPTER 3

### ELEMENTS IN AN HF RADIO SYSTEM

Now that you have an overview of how radio waves propagate, let's take a look at how they are generated. The primary components in a basic HF radio fall into three groups: transmitters, receivers, and antennas. In most tactical radio sets, the transmitter and receiver are contained in a single unit called a transceiver. In large, fixed systems, transmitting stations and receiving stations are customarily at separate locations, often controlled from a remote third site.

#### TRANSMITTER

Although transmitters may vary widely in their configuration, they all consist of an exciter and power amplifier (**Figure 3-1**). The exciter synthesizes a carrier that is modulated by a lower frequency signal derived from a source of information such as a microphone. The resulting signal is converted to the frequency that is to be transmitted. The power amplifier boosts the output power of the signal to the desired wattage for transmission before sending it through an RF cable to the transmitting antenna.

The transmitter may also contain filters that are used to "clean up" its output. A bandpass filter removes noise, spurious signals, and harmonics generated in the exciter or output frequency harmonics coming from the power amplifier. This reduces interference with other radios located at the same site and adjacent communications channels.

#### RECEIVER

All modern HF receiving systems include an RF input filter/amplifier, a series of frequency converters and intermediate frequency (IF) amplifiers, a demodulator, and a local oscillator frequency synthesizer (see **Figure 3-2**). To function, the receiver selects a desired signal, amplifies it to a suitable level, and recovers the information through the process

**FIGURE 3-1** | Transmitters Excite and Power Amplifier

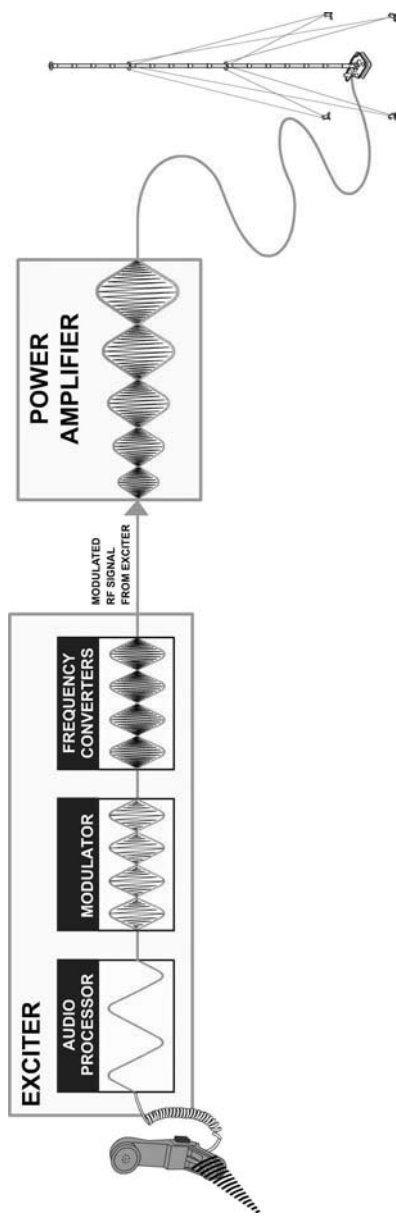

**FIGURE 3-2 | Receivers: Receiver Components**

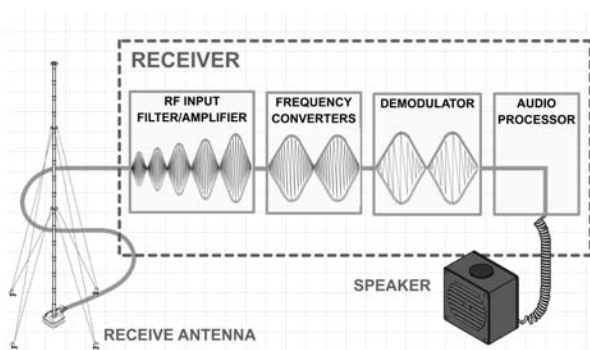

of demodulation, in which the original modulating signal is recovered from a modulating carrier. With contemporary radio equipment, most of these functions are performed digitally.

In order to filter out noise and undesired signals, the RF input stage sometimes incorporates a tunable preselector (a bandpass filter). The filtered signal is then amplified and converted to another frequency for further processing.

But the filtering process does not end here. Typically, the received signal is filtered and amplified again at several different intermediate frequencies. The amplification provided in these stages is a variable that depends on the strength of the received signal.

To output voice, the demodulator produces an audio frequency (base-band) signal that can interface with additional equipment. Also, because the strength of the input signal may not be constant, the demodulator stage produces a voltage proportional to the level of the RF input signal. To compensate for changes in the signal, the voltage is fed back to the RF and IF amplifiers for automatic gain control (AGC), to maintain a constant input to the demodulator.

## ANTENNA

The antenna is one of the most critical elements in a radio circuit. Here, we will look at typical antenna types and their applications.

### ANTENNA CHARACTERISTICS AND PARAMETERS

Some commonly used terms to describe antennas are impedance, VSWR, gain, radiation pattern, take-off angle, and polarization.

Every antenna has an input impedance, which represents the load to be applied to the transmitter. This impedance depends upon many factors, such as antenna design, frequency of operation, and location of the antenna with respect to surrounding objects.

The basic challenge in radio communications is finding ways to get the most power, where and when you need it, to generate and transmit signals. Most transmitters are designed to provide maximum output power and efficiency into a 50 Ohm load. (Ohm is a unit of measurement of resistance.) Some antennas, such as log periodic antennas, can provide a 50 Ohm load to the transmitter over a wide range of frequencies. These antennas can generally be connected directly to the transmitter. They are often referred to as broadband antennas. Other antennas, such as dipoles, whips, and long-wire antennas, have impedances that vary widely with frequency and the surrounding environment. In these cases, an antenna tuner or coupler is required. This device is inserted between the transmitter and antenna to modify the characteristics of the load presented to the transmitter so that maximum power is transferred from the transmitter to the antenna.

The gain of an antenna is a measure of its ability to focus the energy it radiates in a particular direction. The gain is determined by comparing the level of signal received against the level that would be received from an isotropic (or ideal) antenna, which radiates equally in all directions. Gain can be expressed in dBi; the higher this number, the greater the directivity of the antenna. Transmitting antenna gain directly affects transmitter power requirements. If, for example, an omnidirectional antenna were replaced by a directional antenna with a gain of 10 dBi, a 100 Watt transmitter would produce the same effective radiated power (ERP) as a 1 kW transmitter and omnidirectional antenna.

In addition to gain, radio users must understand the radiation pattern of an antenna for optimal signal transmission. Radiation pattern is determined by an antenna's design and, in the HF band, the pattern is strongly influenced by its location with respect to the ground. It may also be affected by its proximity to nearby objects such as buildings and trees. In most antennas, the pattern is not uniform, but is characterized by lobes (areas of strong radiation) and nulls (areas of weak radiation). These patterns are generally represented graphically in terms of plots in the vertical and horizontal planes (**Figure 3-3**), which show antenna gain as a function of elevation angle (vertical pattern) and azimuth angle (horizontal plot). The radiation patterns are frequency dependent, so plots at different frequencies are required to fully reveal the radiation pattern of an antenna.

**FIGURE 3-3 |** Antenna Properties: Radiation Pattern

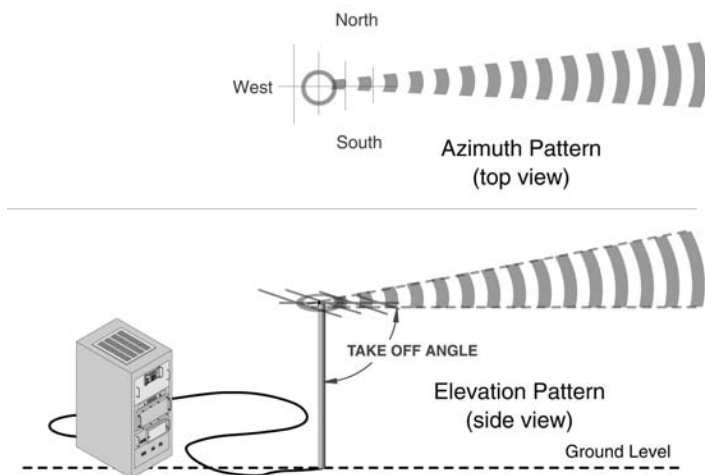

In determining communications range, it is important to factor in the take-off angle, which is the angle between the main lobe of an antenna pattern and the horizontal plane of the earth's surface. Low take-off



angles are generally used for long-haul communications; high take-off angles are used for shorter-range communications.

The orientation of an antenna with respect to the ground determines its polarization. Most HF antennas are either vertically or horizontally polarized. A vertically polarized antenna produces low take-off angles and is therefore suitable for ground waves and for long-haul sky wave links. Vertical antennas commonly require a ground plane, such as a conductive vehicle or ground screen.

A horizontally polarized antenna radiates at higher take-off angles and is suitable for shorter range communications, out to about 500 km. These short range paths are commonly referred to as “Near Vertical Incidence Skywave” (NVIS) paths. By adjusting the height of the antenna above ground, it is possible to increase gain at lower take-off angles for longer-range sky wave performance. Horizontally polarized antennas are largely independent of ground conductivity, and are less affected by local noise than vertical antennas.

For ground wave propagation, the transmitting and receiving antennas should have the same polarization for best results. For sky wave propagation, the polarization of the antennas need not be the same, since the signal polarization will rotate during ionospheric refraction.

## TYPES OF ANTENNAS

There is a countless variety of antennas used in HF communication. We’ll focus here on some of the more common types.

The vertical whip antenna is ideal for ground wave circuits, since it is omnidirectional, has low take-off angles, and is vertically polarized. A typical vertical whip radiation pattern is shown in **Figure 3-4**. Note that the outline of the “doughnut” represents the radiated power. For example, there is virtually no power being radiated off the top of the antenna. The chart below the “doughnut” shows the radiation pattern and gain of the antenna at the various take off angles. The radiation pattern for a vehicle with a vertical whip is shown in **Figure 3-5**. The null (hole) in the overhead pattern for this vehicular configuration is

**FIGURE 3-4 | Vertical 4.7m Whip, Average Ground**

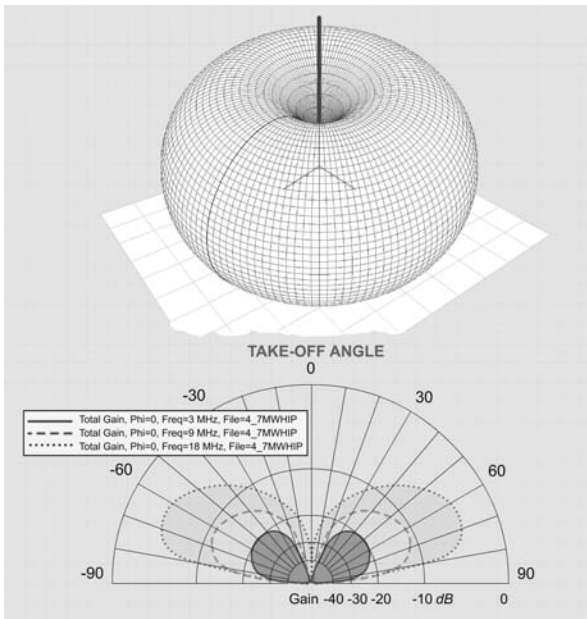

**FIGURE 3-5 | Vertical Whip on Vehicle**

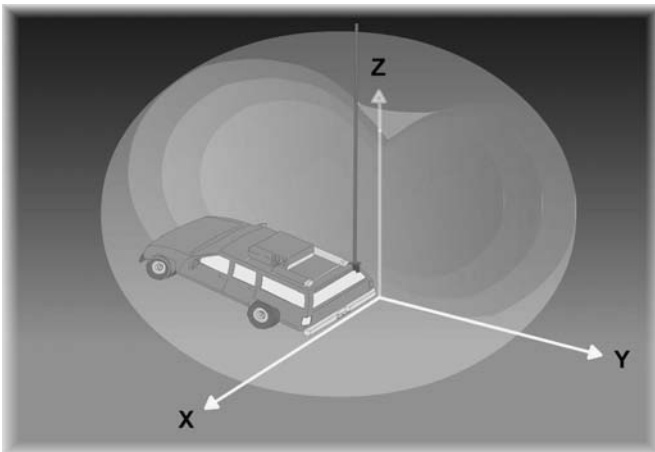

**FIGURE 3-6** | Forward Bent Whip on Vehicle

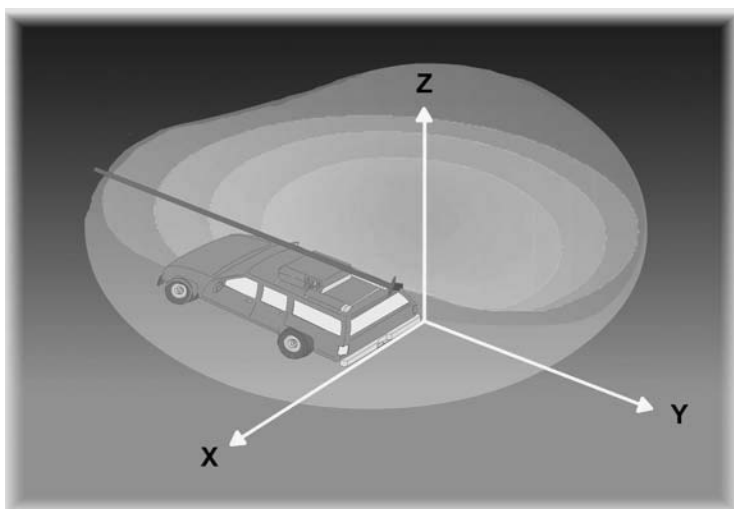

**FIGURE 3-7** | Backward Bent Whip on Vehicle, 4 MHz

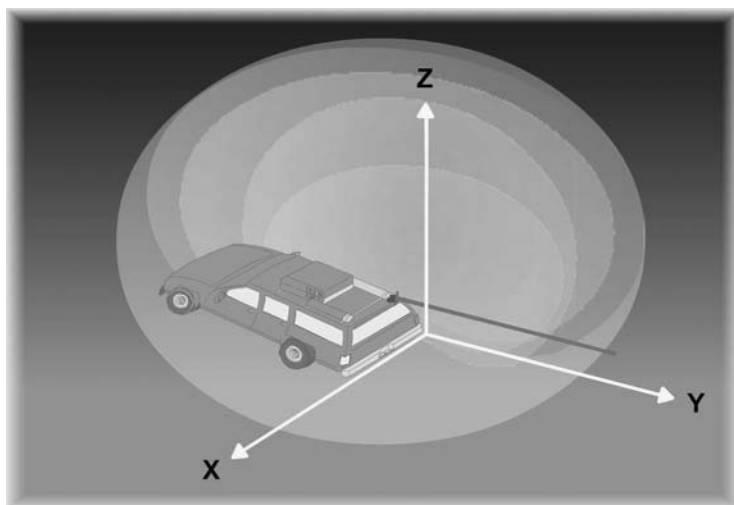

**FIGURE 3-8** | Center-Fed Horizontal Dipole

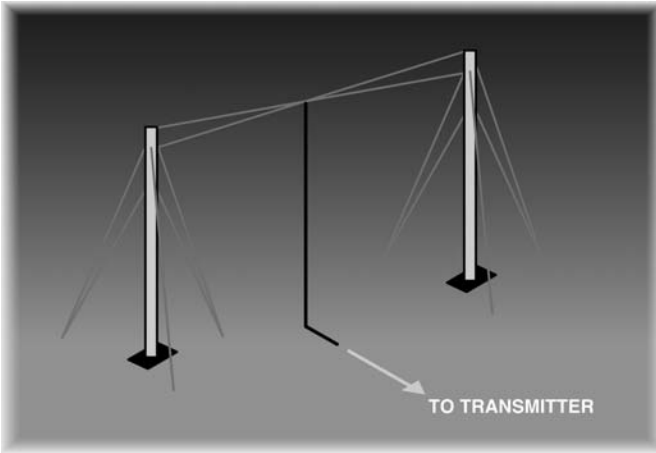

**FIGURE 3-9** | Horizontal Dipole Antenna, Elevation Radiation Patterns

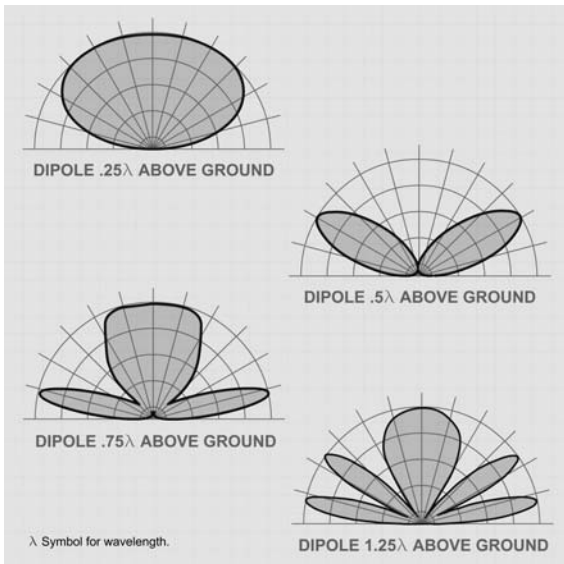

clearly shown. A tilt-whip adapter is a device that allows the antenna to be bent over at a variety of angles which modifies the radiation pattern to be ideal for skywave operation. Bending the whip forward over the vehicle results in the null being filled in as in **Figure 3-6**. Bending the whip backward away from the vehicle results in the pattern shown in **Figure 3-7**, an even more omnidirectional NVIS-type pattern, but obviously not practical for vehicles in motion.

One of the most versatile types of HF antenna is the half-wave dipole, which is basically a length of wire equal to one-half the transmitting wavelength and excited in the center. The dipole can be oriented to provide either horizontal or vertical polarization. **Figure 3-8** shows a center-fed horizontal dipole antenna. The radiation pattern can change dramatically as a function of its distance above the ground. **Figure 3-9** shows the elevation radiation patterns of a horizontal dipole for several values of its height (in terms of transmitting wavelength) above the ground.

An inverted Vee (sometimes called a “drooping dipole”) produces a combination of horizontal and vertical radiation with omnidirectional coverage. See **Figure 3-10**.

Directional antennas range from simple single-wire configurations like the inverted vee to elaborate multi-wire arrays, including horizontal and vertical log periodic systems; see **Figure 3-11**. Directional antennas are often used in point-to-point links. In systems requiring point-to-point communications to widely dispersed stations, rotatable directional antennas may be used.

Sky wave communications between relatively closely spaced stations may require antennas specially designed for this purpose. These near vertical incidence sky wave (NVIS) antennas have a very high take-off angle, radiating RF energy nearly straight up. The radio waves refract downward to the earth in a circular pattern. NVIS antennas provide omnidirectional coverage out to about 400 km.

**FIGURE 3-10 | Inverted Vee Antenna Elevation Radiation Patterns**

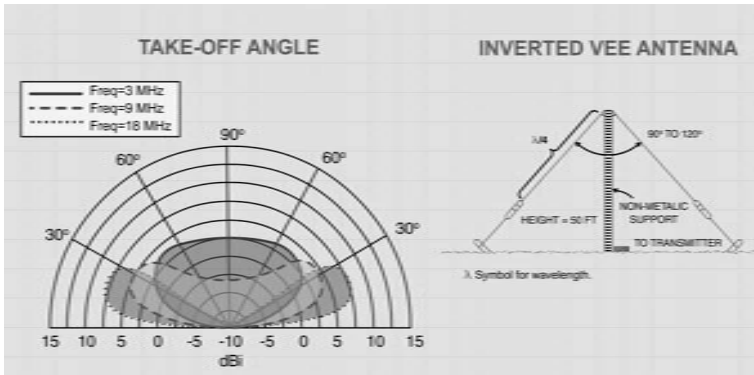

**FIGURE 3-11 | Horizontal Log Periodic Antenna**

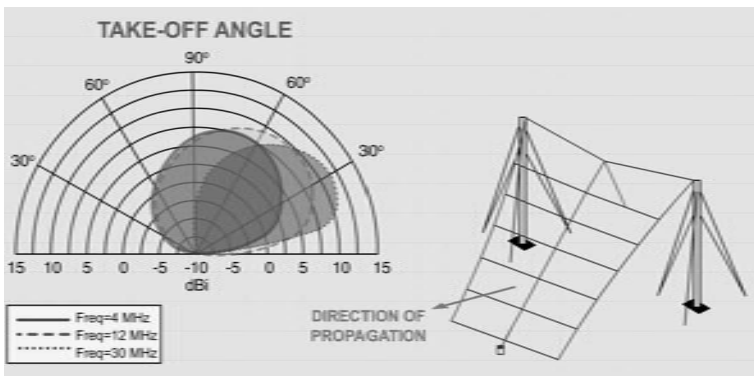

## SUMMARY

A radio system consists of a transmitter, receiver, and antenna group.

The transmitter group consists of an exciter and power amplifier. The exciter includes a modulator, carrier generator, and frequency translator.

The receiver group consists of an RF input filter/amplifier, frequency converters/IF amplifiers, demodulator, and local oscillator.

Antenna selection is critical to successful HF communications. Antenna types include vertical whip, dipole, and directional.

An antenna coupler matches the impedance of the antenna to that of the transmitter, transferring maximum power to the antenna.

The gain of an antenna is a measure of its directivity — its ability to focus the energy it radiates in a particular direction.

Antenna radiation patterns are characterized by nulls (areas of weak radiation) and lobes (areas of strong radiation).

Low antenna take-off angles are generally used for ground-wave and long-haul communications; high take-off angles are used for shorter-range communications.

## CHAPTER 4

### NOISE AND INTERFERENCE

While listening to the radio during a thunderstorm, you're sure to have noticed interruptions or static at one time or another. Perhaps you heard the voice of a pilot rattling off data to a control tower when you were listening to your favorite FM station. This is an example of interference that is affecting a receiver's performance. Annoying as this may be while you're trying to listen to music, noise and interference can be hazardous where a military mission's success or failure depends on hearing and understanding the transmitted message.

Receiver noise and interference come from both external and internal sources. External noise levels greatly exceed internal receiver noise over most of the HF band. Signal quality is indicated by signal-to-noise ratio (SNR), measured in decibels (dB). The higher the SNR, the better the signal quality. Interference may be inadvertent, as in the case of the pilot's call to the tower. Or, it may be a deliberate attempt on the part of an adversary to disrupt an operator's ability to communicate.

Engineers use various techniques to combat noise and interference, including: (1) boosting the effective radiated power, (2) providing a means for optimizing operating frequency, (3) choosing a suitable modulation scheme, (4) selecting the appropriate antenna system, (5) designing receivers that reject interfering signals, and (6) designing data waveforms that function in very poor noise and interference environments. Let's look at some of the more common causes of noise and interference.

#### NATURAL SOURCES OF NOISE

Lightning is the main atmospheric (natural) source of noise. Atmospheric noise is highest during the summer and greatest at night, especially in the 1.6 to 5 MHz range. Average values of atmospheric noise, as functions of time of day and season, have been determined for locations around the world, and are used in predicting HF radio sys-



tem performance. Another natural noise source is galactic or cosmic noise, generated in outer space. It is uniformly distributed over the HF spectrum, and dominates the noise floor above 20 MHz.

### MAN-MADE NOISE

Power lines, computer equipment, and industrial and office machinery produce man-made noise, which can reach a receiver through radiation or by conduction through power cables. This type of man-made noise is called electromagnetic interference (EMI) and it is highest in urban areas. Grounding and shielding of the radio equipment and filtering of AC power input lines are techniques used by to suppress EMI.

### UNINTENTIONAL INTERFERENCE

At any given time, thousands of HF transmitters compete for space on the radio spectrum in a relatively narrow range of frequencies, causing interference with one another. Interference is most severe at night in the lower bands at frequencies close to the MUF. The HF radio spectrum is especially congested in Europe due to the density of the population.

A major source of unintentional interference is the collocation of transmitters, receivers, and antennas. It's a problem on ships, for instance, where space limitations dictate that several radio systems be located together. Ways to reduce collocation interference include carefully orienting antennas, using receivers with filters and using transmitters that are designed to minimize interference.

Signals from a transmitter can reach the receiver via multiple paths (**Figure 4-1**). This causes fading, a variation in average signal level because these signals may add or subtract from each other in a random way. Normally, multipath does not effect analog voice. However it can have an adverse effect on data and digital voice communication. Today, engineers overcome this problem by designing data waveforms that are resistant to the effects of multipath and fading.

## INTENTIONAL INTERFERENCE

Deliberate interference, or jamming, results from transmitting on operating frequencies with the intent to disrupt communications. Jamming can be directed at a single channel, multiple channels, or wider bandwidths. It may be continuous (constant transmitting) or look-through (transmitting only when the signal to be jammed is present). Modern military radio systems use spread-spectrum techniques to overcome jamming and reduce the probability of detection or interception. Three techniques are employed to defeat this threat: spread spectrum, tone excision, and frequency hopping. Spread-spectrum techniques cause the modulated information to be transmitted in a bandwidth considerably greater than the frequency content of the original information. Software-based tone excision techniques are applied with some modems to eliminate interfering tones, some as high as 40 dB above the signal. Frequency hopping is a special mode of a radio in which all radios in the net change frequencies quickly and synchronously to avoid intentional jamming. We'll look at these techniques in **Chapters 8 and 9**.

**FIGURE 4-1** | The Ionosphere: Multipath Spread

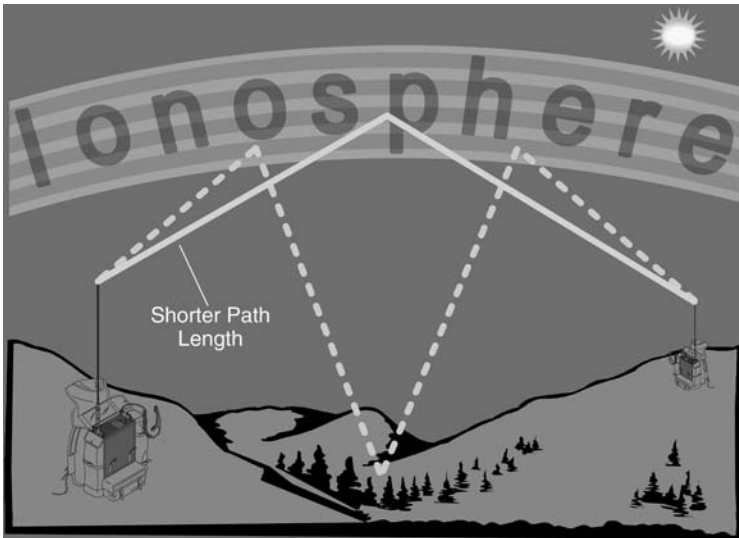

## **SUMMARY**

Natural (atmospheric) and man-made sources cause noise and interference. Lightning strikes are the primary cause of atmospheric noise; power lines, computer terminals, and industrial machinery are the primary cause of man-made noise.

Congestion of HF transmitters competing for limited radio spectrum in a relatively narrow range of frequencies causes interference. It is generally worse at night in lower frequency bands.

Multipath interference causes signal fading.

Collocated transmitters interfere with each other, as well as with nearby receivers.

Jamming, or deliberate interference, results from transmitting on operating frequencies with the intent to disrupt communications.

## CHAPTER 5

### HF MODEMS

From the very beginning, HF radio used Morse code for data communications. Over time, improved techniques were developed for data transmission that take into account the variability of the HF medium and greatly increase the speed at which data transmission occurs over a radio link. In addition, the application of error-correcting codes and automatic repeat request (ARQ) techniques offering error-free data transfer permits the use of HF radio in computer-to-computer communications systems.

HF Data Systems have seen dramatic advancement since the late 90's. Modem (from MODulator/DEModulator) technology has improved both in capacity and robustness. New ARQ techniques and protocols have been perfected and standardized. This chapter discusses modem technology used in data systems. Note that there are a significant number of standardized HF modem waveforms.

To understand the principles of HF data communication, we'll define some common data terminology and explain the significance of the modem. We will also outline some of the problems and solutions associated with HF data communication.

#### BINARY DATA

Communication involves the transfer of information from a transmitter to a receiver over a suitable channel. Consider this book, for instance. It uses symbols (the alphabet) to encode information into a set of code groups (words) for transmission over a channel (the printed page) to a receiver (the reader). Applying this principle to data transmission, we begin by using a kind of shorthand to transform the data into code words (binary digits, or bits) for transmission over a channel, (HF radio) to a receiver, (the operator).

Bits are part of a number system having a base of two that uses only the symbols 0 and 1. Thus, a bit is any variable that assumes two distinct states. For example, a switch is open or closed, a voltage is positive or negative, and so on.

A simple way to communicate binary data is to switch a circuit off and on in patterns that are interpreted at the other end of a link. This is essentially what was done in the early days of telegraphy. Later schemes used a bit to select one of two possible states of the properties that characterize a carrier (modulated radio wave) — either frequency or amplitude. More sophisticated approaches allow the carrier to assume more than two states and hence to represent multiple bits.

### BIT RATE

Data transmission speed is commonly measured in bits per second (bps).

The maximum bit rate that can be supported by a radio channel depends on its bandwidth — the greater the bandwidth, the greater the bit rate.

### ASYNCHRONOUS AND SYNCHRONOUS DATA

The transmission of data occurs in either an asynchronous or a synchronous mode, as defined below.

In asynchronous data transmission, each character has a start and stop bit (**Figure 5-1**). The start bit prepares the data receiver to accept the character. The stop bit brings the data receiver back to an idle state.

Synchronous data transmission eliminates the start and stop bits. This type of system typically uses a preamble (a known sequence of bits, sent at the start of a message, that the receiver uses to synchronize to its internal clock) to alert the data receiver that a message is coming. Asynchronous systems eliminate the need for complex synchronization circuits, but at the cost of higher overhead than synchronous systems. The stop and start bits increase the length of a character by 25 percent,

**FIGURE 5-1** | Asynchronous Data Systems Waveforms

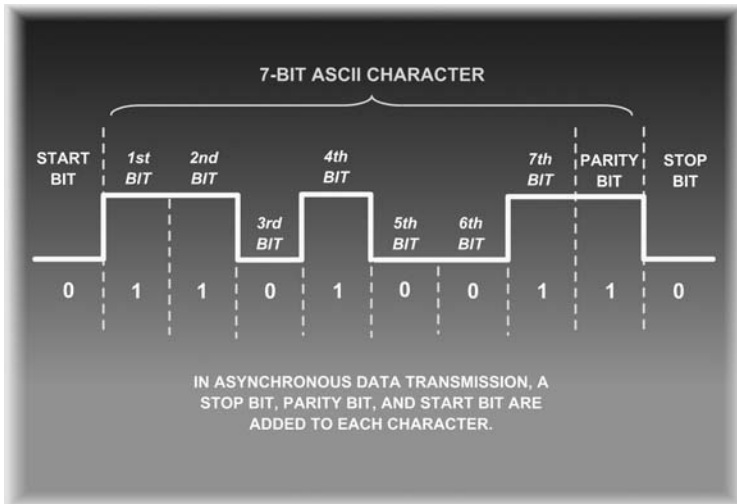

**FIGURE 5-2** | Frequency Shift Keying Waveforms

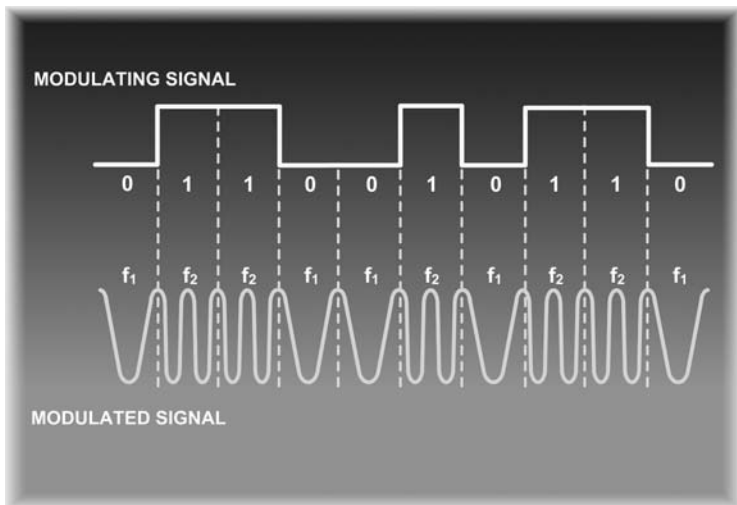

from 8 to 10 bits. Most high speed HF modems are used in synchronous data mode.

### HF MODEM TECHNOLOGY

Most older voice radios cannot transmit data directly. Data digital voltage levels must be converted to audio, using a device called a modulator, which applies the audio to the transmitter. Conversely, at the receiver, a demodulator converts audio back to digital voltage levels. Newer radios are equipped with built-in high-speed modems which permit the radios to operate with either voice or data inputs.

HF modems fall into three basic categories: (1) modems with slow-speed frequency shift keying (FSK); (2) mid-rate 2400 bps modems; and (3) high-rate 9600 bps modems.

The simplest modems employ FSK to encode binary data (0s and 1s) (see **Figure 5-2**). This is often referred to as "Binary FSK". The input to the modulator is a digital signal that takes one of two possible voltage levels. The output of the modulator is an audio signal that is one of two possible tones. HF FSK systems are limited to data rates of 600 bps or less due to the effects of multipath propagation. Higher rates are possible with multi-tone FSK (MFSK), which uses a greater number of tones (in-band frequencies).

2400 bps HF modem technology, using both parallel and serial tone waveforms to allow transmission of data from 75-2400 bps, was pioneered by Harris in the early 1980s. The serial tone modem carries information on a single audio tone. This technology was made possible by the emergence of Digital Signal Processors (DSPs) to modulate and demodulate the waveform. It provides vastly improved data communications than Binary FSK Modems on HF channels, due to greater robustness, reduced sensitivity to interference, and a higher data rate with powerful forward error correction (FEC). Parallel tone modems send several tones at once, each carrying information.

Most users of have abandoned parallel tone implementations due to better serial tone performance and availability of commercial off-the-shelf (COTS) products.

A new generation of higher speed waveforms was developed in the late 90's to provide reliable communications from 3600 to 9600 bps in a single 3-kHz channel. A two-channel version of the modem can provide rates as high as 19,200 bps. These waveforms are documented in MIL-STD-188-110B and STANAG 4539. Note that while the high-speed modems are significant breakthroughs over HF, they do require good channel conditions for acceptable bit error rates. Consequently, the current generation of data systems dynamically adapt the data rate to the available channel.

## ERROR CONTROL

Several different approaches are utilized to avoid data transmission problems. Forward Error Correction (FEC) coding adds redundant data to the data stream to allow the data receiver to detect and correct errors. An important aspect of this concept is that it does not require a return channel for the acknowledgment. If a data receiver detects an error, it simply corrects it and accurately reproduces the original data without notifying the data sender that there was a problem. In general, adding more coding allows more errors to be detected and corrected. The cost for this is increased overhead.

The FEC coding technique is most effective if errors occur randomly in a data stream. The HF medium, however, typically introduces errors that occur in bursts — that is, intervals with a high bit error ratio (BER) in the channel are interspersed with intervals of a low BER. To take full advantage of the FEC coding technique, it's best to randomize the errors that occur in the channel by a process called interleaving (**Figure 5-3**).

For example, at the modulator, the data stream enters a 9-row by 10-column matrix. The blocks are entered by rows and unloaded by columns. When the data stream leaves the matrix for transmission, the sequence of output bits will be 1, 11, 21, and so on.

At the demodulator, the process is reversed by de-interleaving. Data is entered by columns in a matrix identical to that at the transmitter. It is read out in rows, restoring the sequence of data to its original state.



Thus, if a burst were to cause 9 consecutive bits to be in error, no more than 3 of them would fall in any 30-bit sequence of bits after de-interleaving. Then, if an FEC coding technique were used, the errors would be corrected. Put simply, interleaving mixes up all of the transmitted bits so that the errors are distributed randomly and can be corrected by FEC.

**FIGURE 5-3 | Interleaving Operation**

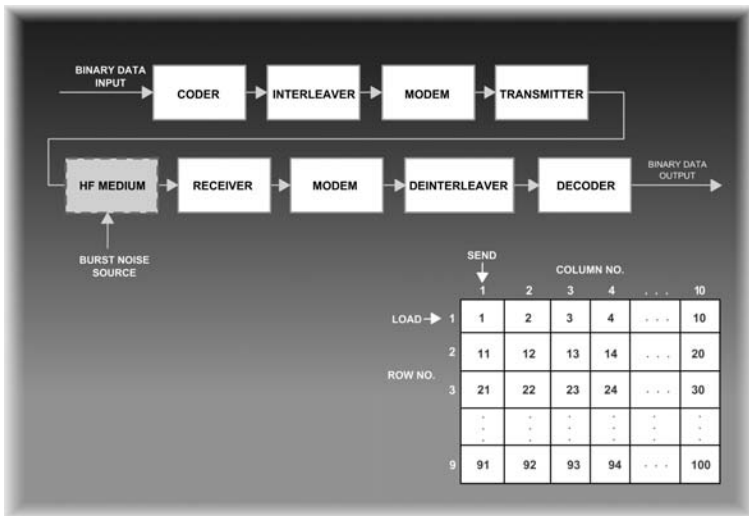

Soft-decision decoding further enhances the power of the error-correction coding. In this process, a group of receive symbols are compared against the set of possible transmitted code words. The system “remembers” the voltage from the detector and applies a weighing factor to each symbol in the code word before making a decision about which code word was transmitted.

Soft-decisions allow the demodulator to reduce the number of data errors by making a “better guess” based on all the information received.

In addition to error-correction techniques, high-speed serial modems may include two signal processing schemes that improve data transmissions. An automatic channel equalizer compensates for variations in the channel characteristics as data is being received. An adaptive excision filter seeks out and suppresses narrowband interference in the demodulator input, reducing the effects of co-channel interference, that is, interference on the same channel that is being used.

Modern day HF modems are microprocessor controlled and are capable of generating many kinds of waveforms. The standard suite of military waveforms are listed below. The standards are further discussed in **Appendix A**.

---

MIL-STD-188-110B, APP. C/ STANAG 4539: Coded PSK/QAM at 3200, 4800, 6400, 8000, 9600 bps, Uncoded QAM at 12800 bps

---

MIL-STD-188-110B, APP. B: Coded 39 Tone QDPSK at 75, 150, 200, 600, 1200, 2400 bps

---

STANAG 4285: Coded PSK at 75, 150, 300, 600, 1200, 2400 bps, Uncoded PSK at 1200, 2400, 3600 bps

---

MIL-STD-188-110B: Coded Serial Tone PSK at 75, 150, 300, 600, 1200, 2400 bps, Serial Tone Uncoded PSK at 4800 bps

---

STANAG 4529: Coded PSK at 75, 150, 300, 600 1200 bps  
Uncoded PSK at 600, 1200, 1800 bps

---

STANAG 4415: Coded PSK at 75 bps (NATO Robust Waveform)

---

STANAG 4481: Coded PSK at 300 bps

---

MIL-STD-188-110B FSK: 50 to 600 bps (variable shift)

---

## SUMMARY

The transmission of data requires the use of modems to convert digital data into analog form when transmitting, and convert analog data back to digital form when receiving.

HF modems are classified as slow-speed FSK, mid-rate 2400 bps, or high-rate 9600 bps.

Serial tone modems provide vastly improved data communications on HF channels, including a higher data rate with powerful forward error correction (FEC), greater robustness, and reduced sensitivity to interference.

FEC systems provide error correction without the need for a return link.

Interleaving is a technique that randomizes error bursts, allowing FEC systems to work more effectively.

Soft-decision decoding further reduces bit error rates by comparing a group of symbols that retain their analog character against the set of possible transmitted code words.

Automatic channel equalization and adaptive excision filtering are signal processing techniques that improve data communications performance.

## CHAPTER 6

# **AUTOMATIC LINK ESTABLISHMENT (ALE) TECHNOLOGY**

The constantly changing properties of the ionosphere, as well as random noise and interference, cause disruptions in HF communications. In the past, a skilled radio operator was required to establish communications and to continually adjust operating parameters. Today, this function is fully automatic. ALE-based systems react rapidly to changing propagation conditions and use feedback from Real Time Channel Evaluation (RTCE) techniques to select frequencies, adjust data rates, or change modulation schemes.

### **ALE HISTORY**

With the advent of the microprocessor age, Harris and two other companies developed the first generation of “adaptive HF” systems in the early 80’s. The Harris Autolink® system was one of the first automated HF systems available. As the first generation systems began to be fielded, the US government became concerned that systems manufactured by different vendors would not interoperate. Mitre Corporation was tasked to develop a second generation ALE waveform that manufacturers could design to. The objective was to provide interoperability between equipment supplied by different vendors and to provide performance improvements over the first generation systems. Harris developed the rapid prototype of the new waveform that was used by the US Government to validate the system. The resulting (nearly identical) standards, MIL-STD-188-141A and FED-STD-1045 were released in the late 80s. Dozens of manufacturers have implemented these standards into their radios and they have become the de-facto worldwide standards for ALE.

In the late 90s it became clear that second generation ALE had limitations for use with data and large networks. New data capabilities, including more robust modems, the emergence of the tactical internet, and extensive HF e-mail networks required higher speed linking, better performance in poor channels, and improved channel access. To

address this need, NATO and the US Government developed a third generation ALE system now commonly known as STANAG 4538. Harris was a principal in the development of this technology and the first to offer it commercially. STANAG 4538 is described in more detail in **Chapter 8**.

### ALE OPERATION

ALE is a technique that permits HF radio stations to call and link on the best HF channel automatically. Typically, ALE systems make use of recently measured radio channel characteristics (LQA data) stored in a memory “matrix.” The system works much like a telephone in that each radio in a network is assigned an address. When not in use, each radio receiver constantly scans through its assigned frequencies, listening for calls addressed to it.

To reach a specific station, the caller simply selects an ALE address, just like dialing a phone number. The radio consults its LQA matrix and selects the best available assigned frequency. It then sends out a brief message containing the destination address. When the receiving station “hears” its address, it stops scanning and stays on that frequency. The two stations automatically conduct a “handshake” to confirm that a link is established and they are ready to communicate (**Figure 6-1**). The receiving station, which was completely silent while scanning, will typically emit a ringing signal to alert the receiving operator of an incoming call. At the conclusion of the call, one of the stations “hangs up” a disconnect signal is sent to the other station, and they each return to the scanning mode. If the units don’t link on the first selected channel, the system selects the next best channel from the LQA matrix and calls. This process is repeated until the systems link, or the channel list is exhausted.

### LINK QUALITY ANALYSIS (LQA) AND SOUNDING

An HF communications system has a number of channels assigned to it. A system incorporating LQA capability selects the best channel. Here’s how it works in a modern HF radio.

**FIGURE 6-1 | ALE Systems Handshake**

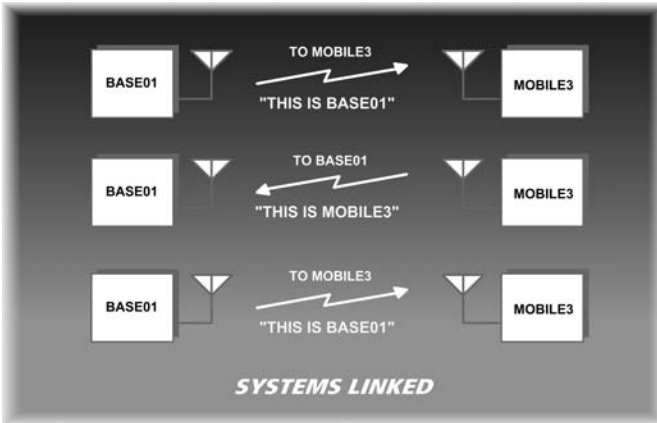

**FIGURE 6-2 | LQA Matrix for Base 01**

ADDRESS	CHANNELS				
	01	02	04	14	18
ADDRESS	60	33	12	81	23
MOBILE2	10	--	48	86	21
MOBILE3	--	--	29	52	63
GBB122	21	00	00	45	--

At programmed intervals, a station in a network will attempt to link with another station on each of its assigned frequencies and measure the signal quality. These quality scores are stored in a matrix. When a call is initiated, the radio checks its “LQA matrix” to determine the best frequency to call the desired station. It then attempts to link on that frequency. If the link cannot be established, it will try again on the next best frequency, and so on, until a link is established.

**Figure 6-2** shows a simplified LQA matrix for station BASE01. The channel numbers represent programmed frequencies, and the numbers in the matrix are the most recent channel-quality scores. Thus, if an operator wanted to make a call from BASE01 to MOBILE03, the radio would attempt to call on channel 18, which has the highest LQA score.

When making multi-station calls, the radio selects the channel with the best average score. Thus, for a multi-station call to all the addresses in the matrix, channel 14 would be selected.

The difference between an Exchange and a Sound is that an Exchange is a bi-directional test, whereas a Sound is a one-way broadcast. Exchanges are typically used when there is regular traffic between two specific points. Sounds are often used where there is a central site that all “outstations” call into or in larger networks.

## SECOND GENERATION ALE

As discussed above, second generation ALE is synonymous with MIL-STD-188-141B Appendix A. There are tens of thousands of interoperable radios in the world. The system provides modestly robust signaling (links to about 2 dB SNR), flexible addressing, simple embedded messaging, and asynchronous scanning. It has a simple modulation scheme (8-ary FSK) and is relatively easy to implement. Data systems that employ second generation ALE typically will link and then pass traffic off to a separate data modem as shown in **Figure 6-3**.

**FIGURE 6-3** | Typical Second Generation System

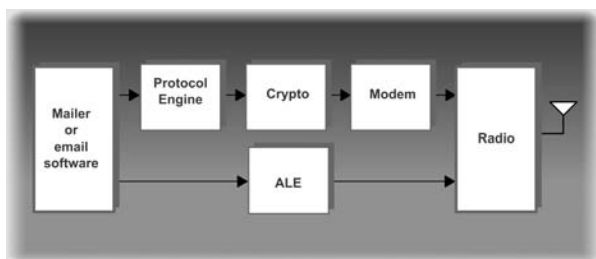

### THIRD GENERATION ALE

The terms “STANAG 4538” and “third generation” (3G) ALE are often used interchangeably. The third generation system is a different concept from second generation. Several key changes were made to dramatically improve system performance and to accommodate the new generation of data applications centered on tactical internets. The key differences are:

**Integrated ALE and data.** STANAG 4538 is both an ALE and Data Link standard. The two functions utilize a common suite of waveforms. This provides the ability to quickly switch between functions, saving on-the-air time and reducing channel contention. The data link utilizes code combining and black-side ARQ techniques to improve throughput. These items are discussed in greater detail in **Chapter 7**.

**Robust signaling.** 3G takes advantage of waveform advancements and processing power improvements made through the 90s. It will link and pass data in channels with SNRs lower than  $-5$  dB SNR. This is particularly important for use with ground mobile platforms where systems often use poor antennas at low power.

**Synchronous operation for faster linking.** STANAG 4538 systems are normally synchronized. This eliminates the long preamble of the second generation systems. The result is a typical linking time of about 6 seconds versus a typical 12 seconds for MIL-STD-188-141B. This improvement is very important in tactical networks where there are many short messages being delivered simultaneously. Provisions are



made for asynchronous calling in the event that station(s) are not synchronized, but it requires a longer time to link.

## **LINK PROTECTION**

Link protection (LP) is the scrambling of ALE signaling. In strict terms, it is not a COMSEC or TRANSEC function and it is often called LINKSEC. Link Protection has two purposes: anti-spoofing and address protection. An ALE system is vulnerable to spoofing from an automated system or simply from a tape recorder. For example, an adversary could simply record a link termination transmission to your system off-the-air and play it back over-the-air when your system is linked. Your system would properly interpret the transmission as a "return to scan" message and do just that. Secondly, if address information is sent in the clear, an adversary could know both your address and the address of the station you are talking to.

Link Protection addresses both these issues by scrambling the on-air ALE bits. All units in a net have the LP key and can decode the incoming signals. The scrambling changes periodically (every "Protection Interval") to defeat the tape recorder attack. Second generation LP is defined in the optional MIL-STD-188-141B Appendix B — it utilizes a 2 second to 60 second Protection Interval depending on the level of security. Third Generation LP is an integral part of STANAG 4538 and is included in all compliant designs.

## **USE OF ALE IN SYSTEMS**

ALE has become a standard component of automated systems. It is routinely used to set up the channel for voice communications, telephony, e-mail, and IP traffic. It effectively provides a channel access mechanism and provides an effective way to utilize several channels simultaneously. It can also be used to determine the initial data rate for second generation data systems such as STANAG 5066.

## **SUMMARY**

ALE radio technology permits modern HF radio systems to adjust automatically to changing propagation conditions.

Automatic Link Establishment (ALE) makes it possible for HF radios to connect without operator assistance.

Link Quality Analysis (LQA) Exchange and Sounding are methods of assessing channel quality, so that automatic linking occurs on the best channel/frequency.

Second generation ALE (MIL-STD-188-141B Appendix A) is versatile and is fielded in large numbers.

Third Generation ALE combines ALE and data. It is optimized for large ground mobile networks and new data applications like the tactical internet.

Link Protection provides anti-spoofing and address protection for 2nd and 3rd generation ALE.

## CHAPTER 7

### DIGITAL VOICE

Digital voice was introduced into HF radios in the early 1980s. The purpose of it was to provide high grade encryption to voice communications. Prior to this, the standard way to encrypt voice was by use of analog scrambling techniques. This involved “slicing” the 3 kHz voice signals into smaller sub-bands, mixing them up, and then transmitting them. The receiving radio would then reverse the process and recover the voice. Although analog scrambling had good voice quality, it is easy to decipher by adversaries. Digital Voice, on the other hand, is entirely encoded using data and can be fully encrypted as data.

The most popular digital voice technique for HF radio in the 1980s and 1990s was Linear Predictive Coding (LPC). The defacto standard variant of this technique was LPC-10e and became the basis for several secure voice systems. Initially, the LPC was utilized at 2400 bps. Later, 1200, 800, and 600 bps versions were introduced in standardized or proprietary implementations.

The vocoder is the actual implementation of the digital voice encoding and decoding process. A 600 bps vocoder uses different coding techniques than a 2400 bps vocoder. There are definite tradeoffs between the vocoders at different data rates. Because the higher data rates carry more information, the quality of the voice is generally better with a 2400 bps on-air data rate. Further, there is less end-to-end delay because the data exits the crypto and interleaver faster. However, the reason that 600 bps is extremely useful for the HF is that 600 bps can be received in channels with a signal-to-noise ratio (SNR) of almost 10 dB lower than is required for 2400 (see **Figure 7-1**). For the first time, digital voice is more reliable than analog voice. To put it in perspective, the difference in reliability of 2400 bps and 600 bps is close to the difference of a 100W transmitter and a 1kW transmitter. Additionally, interfering tones and tone jammers can be automatically filtered out due to the tone excision capability of the serial tone modems. The benefit to the user is higher reliability and availability, and elimination of noise and interference. Needless to say, this is highly valued by tactical radio operators.

**FIGURE 7-1** | Communications Thresholds in a “Medium” channel

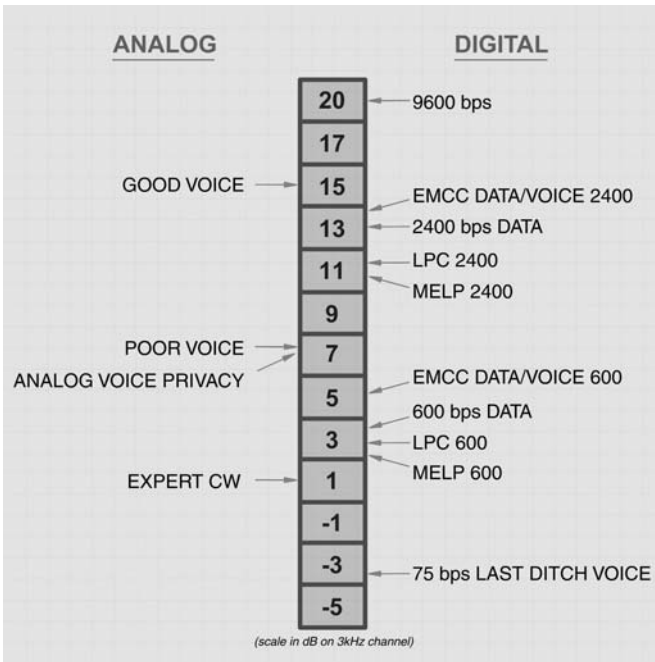

As you might expect, LPC digitized voice in HF radios has some disadvantages. They often include:

- + Poor voice recognition
- + Synthetic voice quality
- + Poor quality with non-English languages
- + High susceptibility to bit errors resulting in garbled audio in poor channels

In the late 90s a new low rate vocoder technology known as Mixed Excitation Linear Prediction (MELP) was developed to address the deficiencies with LPC algorithms. A new 2400 bps algorithm was developed by a consortium led by the US Department of Defense and was standardized in MIL-STD-3005. It uses a number of new voice processing techniques to dramatically improve quality and intelligibility. Harris and other companies subsequently developed a 600 bps variant that

provides very high quality voice with the robustness that 600 bps provides. Standardized vocoder tests were performed by independent test labs and showed that the Harris 600 bps MELP vocoder provides better voice quality and intelligibility than the 2400 bps LPC-10e vocoders.

Whether using an LPC or a MELP vocoder, the system works as shown in **figure 7-2**. The radio operator would initiate an ALE link with another station or stations. When the microphone is keyed and voice is spoken, it is digitally encoded by the vocoder, encrypted, a header is added to the encrypted data to indicate the traffic type, modulated using a serial tone modem, and transmitted by the radio. The process is reversed at the distant end and audio is played out at the speaker. The receiving radio automatically detects the data rate, the vocoder, and determines which key to use to decrypt the transmission. If more than one radio was linked, all radios that received the transmission would “play it.”

**FIGURE 7-2 | Digital Voice System**

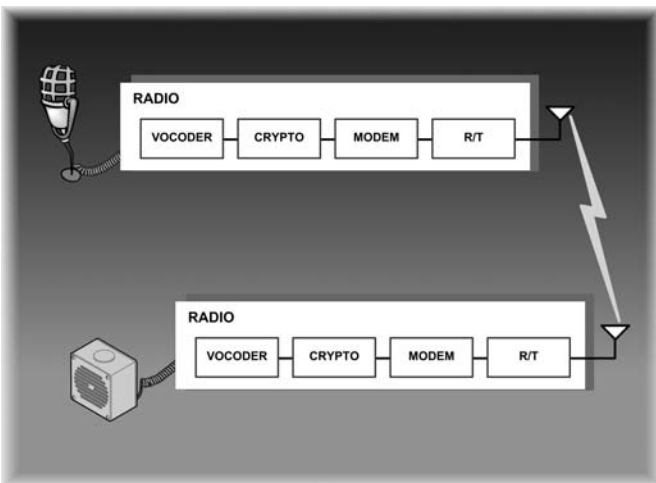

## **SUMMARY**

The first digital voice systems were designed to provide secure voice.

LPC-10e based vocoders were standardized in the 80s and 90s and were fielded in large numbers.

The higher data rate of vocoders have better voice quality than lower rate vocoders of their same type, and have lower end-to-end delays.

600 bps vocoders provide significantly better reliability than 2400 bps.

MELP vocoders have been fielded recently and provide enhanced voice quality and intelligibility.

600 bps MELP Vocoders provide voice quality superior to that of 2400 bps LPC-10e vocoders, with greatly improved reliability due to the lower data rate.

## CHAPTER 8

### DATA SYSTEMS

In **Chapter 5**, we discussed modem technology. This chapter discusses the data system as a whole. In the mid 90s, when a knowledgeable HF user was asked, "What do you want your HF system to do?" he would have replied, "I want it to be completely automatic. It needs to take my message, compress it, make the link with the right station, send it error-free, while adapting the data rate to get the highest throughput possible. And if something goes wrong, it needs to find a way to get the message through, either by re-establishing the link or sending it through another station." Today's systems do all this and more.

Modern systems utilize the HF modem as a building block and integrate ARQ protocols, adaptive data rate control, ALE control, security architecture, and application protocols to provide a complete, and often interoperable, HF data system. Data is sent to support a wide variety of applications, including chat, email, situational awareness, and others. Some of these can be satisfied simply by broadcasting data using an HF modem. However, many applications require error-free data. Therefore, most data systems utilize a reliable ARQ based data link to ensure that the data gets to the destination(s) properly.

There are two emerging de facto standards for military and government HF data communications: STANAG 5066 and STANAG 4538. Both these standards send error-free data and adapt to the channel conditions to push through as much data as the channel will allow. Both systems can be used to send a variety of data including files, e-mail, and generic Internet Protocol (IP) traffic. How they do it is quite different. Both systems will be discussed in this chapter.

E-mail transmission poses significant challenges to HF radio. The standard internet protocol suite could be used, but it is very inefficient for a bandwidth-limited wireless medium. For example, a simple on-line e-mail can require 17 or more link turnarounds. Throughput will still be poor even using the fastest HF modems. To get around this problem, HF systems convert the standard Simple Mail Transfer Protocol (SMTP)

protocol exchange into a “file.” This technique reduces the email transmission to 3 link turnarounds and dramatically improves throughput. The same approach is used in both STANAG 5066 and STANAG 4538 e-mail systems.

### STANAG 5066

A STANAG 5066 system typically consists of several components including a PC, a modem, a crypto, and a radio with ALE. Often several of these components are integrated in the radio, but they function as individual units as shown in **Figure 8-1**. STANAG 5066 defines a protocol stack for exchanging digital information over HF radio. A simplified conceptual diagram is shown in **Figure 8-2**. Normally, the STANAG 5066 protocols and overall system control is implemented in software that runs on the PC. The standard permits certain options, but the normal (interoperable) configuration is a MIL-STD-188-110B modem including the 75 to 9600 bps waveforms, second generation MIL-STD-188-141B ALE, and a crypto.

The system is capable of sending many types of traffic, such as IP packets, but is typically used to send secure e-mail over HF. When the user at the PC wants to send a message, the STANAG 5066 software will convert the e-mail to “a file” for transmission to the distant end. The STANAG 5066 software will determine what ALE address corresponds to the e-mail address and command the ALE controller to link with the destination. It will then send the file in blocks as shown in **Figure 8-3**, and the destination end will send an acknowledge (ACK) when blocks are received correctly. If there are transmission errors, the destination end will send an ACK after each block indicating which sub-blocks are in error (**Figure 8-4**). The sender will then repeat the sub-blocks in error and add new data as well. Each transmission includes a recommended data rate for the other station to use based on the received SNR and error rate. The sending system adjusts its data rate each time it transmits. The data rate adapts in this way to dynamically adjust to changes in channel conditions to get the highest throughput possible. When the file is completely sent, the software will command the ALE controller to terminate the link. The receiving unit will convert the message back into Simple Mail Transfer Protocol (SMTP) and send the message to an embedded or external mail server, where it will be delivered to the destination e-mail application, such as MS Outlook.



**FIGURE 8-1** | Typical STANAG 5066 System Block Diagram

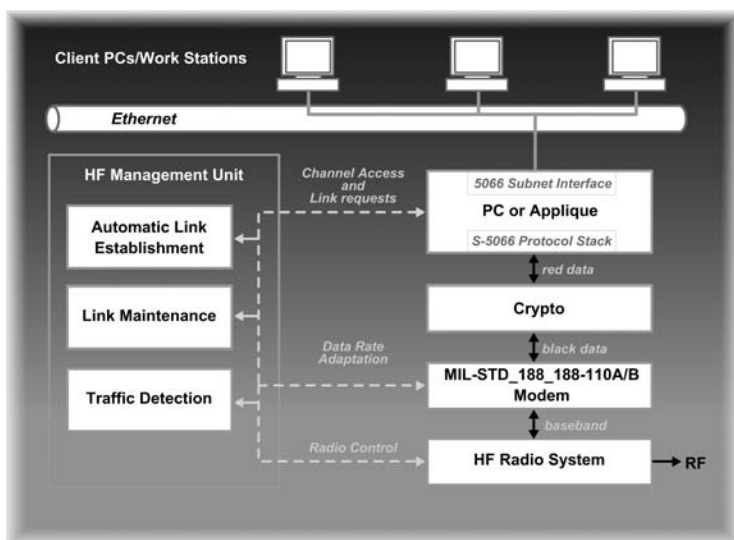

**FIGURE 8-2** | STANAG 5066 Conceptual Block Diagram

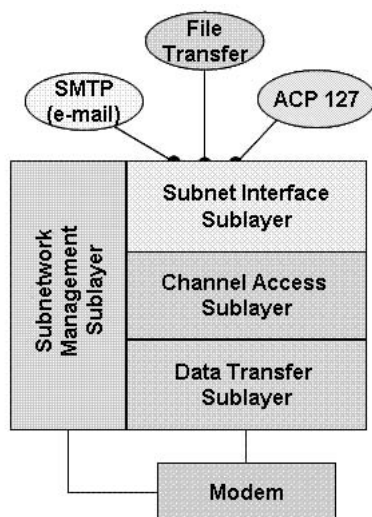

**FIGURE 8-3 | ARQ Transmission without errors**



**FIGURE 8-4 | ARQ Transmission with errors**



STANAG 5066 has become the choice of many military organizations for data communications. This is due to a number of factors, not the least of which is the ability for users to use their existing radio and modem technology, providing a cost effective way to add data capabilities to existing networks. Another important factor that cannot be overlooked is the plentiful number of implementations, and the levels of interoperability they have obtained between various vendors. Implementations such as the Harris “Wireless” data products include STANAG 5066, and associated e-mail standards: Compressed File Transfer Protocol (CFTP), and HF Mail Protocol (HMTP), as well as a socket-based IP client.

### STANAG 4538

STANAG 4538 is a NATO Standardization Agreement (STANAG) defining a unified family of HF waveforms and protocols for linking and data transfer. THE STANAG 4538 waveforms and protocols are Third Generation (3G) HF techniques developed in the late 1990s, which provide improved voice and data communications for the tactical user. They include efficient serial tone burst waveforms, faster and more robust automated linking, and advanced ARQ data link protocols. This

has resulted in significant advances in system performance including faster linking, operation at lower signal-to-noise (SNRs), and improved network capacity.

A typical block diagram of a STANAG 4538 based system is shown in **Figure 8-5**. The components typically consist of a PC and an integrated radio with embedded ALE, modem, crypto, and data link. Normally, only the higher level e-mail protocols run in the PC. The data link protocols are embedded into the radio.

**FIGURE 8-5 | STANAG 4538 Functional Block Diagram**

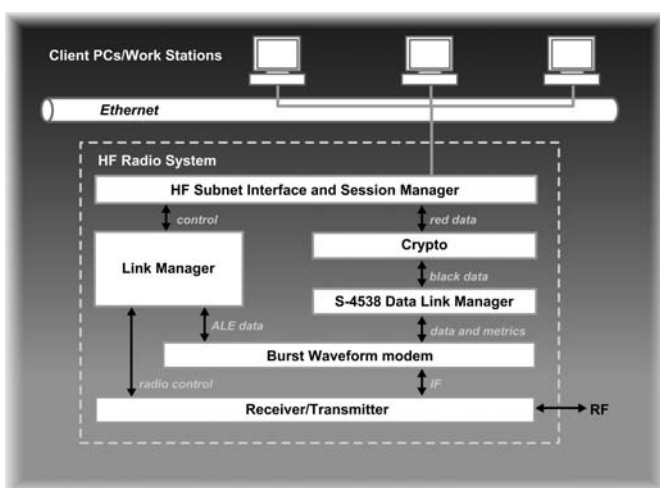

STANAG 4538 systems are well suited to a wide variety of applications such as secure voice, secure e-mail, position reporting/situational awareness, chat messaging, file transfer, and IP data over HF. The STANAG 4538 protocols are used to provide data and voice services in plaintext and ciphertext modes, with COMSEC provided by the radio's embedded crypto module. For data services, there are three STANAG 4538 data link protocols: the High Throughput Data Link protocol (HDL), the Low Latency Data Link protocol (LDL), and the higher-throughput HDL+ data link protocol. The combination of the three pro-

protocols is often referred to as “xDL.” For each transfer, one of these protocols is selected based on the amount and nature of the data to be sent and the current channel conditions. Note that STANAG 4538 can also setup links for other types of data traffic (i.e. STANAG 5066).

The series of actions used to send voice or data in 3G systems is similar to that of 2G systems; however, the system implementation in 3G is more integrated. The architectural differences between typical STANAG 5066 systems and STANAG 4538 systems are illustrated in **Figure 8-6**.

**FIGURE 8-6** | 2G and 3G Data Systems

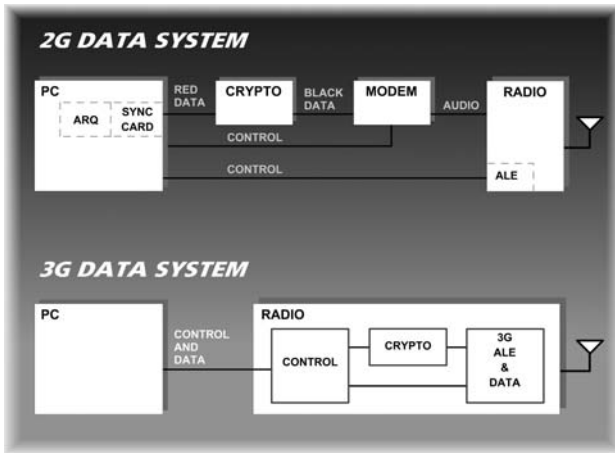

**Figure 8-7** illustrates the process to link, send a message, and terminate the link. Each idle radio is synchronously scanning through pre-assigned channels looking for incoming calls. Synchronization is accomplished using the built-in Time Server protocols or by use of GPS time. When a radio is commanded to send data, the sending radio evaluates the first good channel to determine whether there is any activity on the channel. This is accomplished by constantly monitoring channels during receive scan (dwell) and/or performing a Listen Before Transmit (LBT) prior to calling on the channel. If the channel is free, the calling radio transmits a Call [Fast Link Setup (FLSU) request] at the precise time that the rest of the net is listening to the channel. The called

radio responds with a confirmation (FLSU confirm). The caller radio then delivers the data through a series of xDL forward and xDL acknowledgement transmissions. The data transmission is concluded with a link termination (FLSU termination). In a simple one-way data transfer, the radios then return to scan and are ready to send and receive new data. If there is data to be sent in both directions, the link is held open until all packets are sent in both directions.

**FIGURE 8-7 | 3G Data Transmission Example**

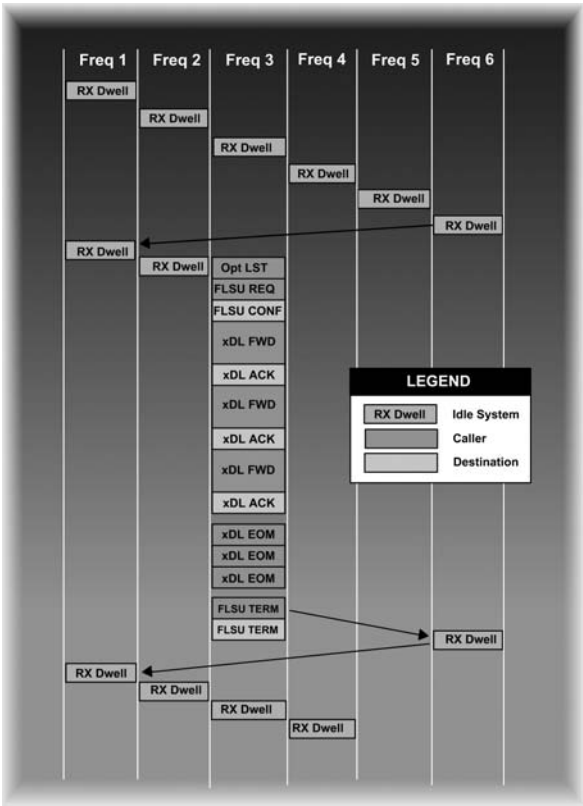

As with 2G systems, voice communications are under the control of the operator. The operator selects the unit or units to communicate with and the radio establishes the link. Digital voice packets are then exchanged in the course of conversation and the proper encryption key and vocoder automatically selected at the receiving end. When one or more of the operators is finished, they terminate the link.

Several factors contribute to the significant performance improvements realized by 3G over the previous generation.

**Synchronization:** The radios are synchronized for both ALE and data transmissions. This allows a radio to eliminate the time consuming and congestion creating “stop scan” preamble of 2G systems and retransmit timeouts are reduced for forward and reverse data transmissions.

**Robustness:** Each of the signaling packets, known as Protocol Data Units (PDUs), is specialized for specific purposes; e.g., calls, acknowledgements. Modulation, coding, Interleaver and data length are optimized for the information they convey.

**Integrated Modem:** The ALE and data waveforms are designed as a family of burst waveforms. This makes it practical for a single modem to implement all functions. In 2G systems, the modem (typically MIL-STD-188-110B or STANAG 4539) and the ALE system (typically MIL-STD-188-141B) are separate implementations and often separate units. The resulting handoff delays between the modem and ALE are a significant source of lost throughput.

**Advanced Data Link Protocol Techniques:** The STANAG 4538 ‘XDL’ data link protocols are incremental redundancy Hybrid-ARQ protocols using a technique commonly known as “code combining.” When a packet is received containing errors, the receiving radio retains the received data symbols from the packet and requests retransmission of the packet. If the packet retransmission also contains errors, the receiving radio combines its symbols with those of the prior packet transmission and is usually able to recover the packet without errors, yielding a significant improvement in throughput under difficult channel conditions.

### BLACK SIDE ARQ

The 3G data system integrates the modem, ARQ (data link manager), and crypto as shown in **Figure 8-8**.

The system utilizes “black side ARQ” to significantly reduce the overhead associated with the crypto. In a “red side ARQ” system as shown in **Figure 8-8**, every transmission is separately encrypted. There is significant overhead added to the data transmitted by the radio. Further, some of the overhead added by the crypto is critical to decrypting the *entire* packet. If any of the important overhead bits are lost, the entire ARQ “burst” transmission is lost. 3G black side ARQ eliminates this critical loss in throughput by encrypting the entire message and then sending the encrypted data ARQ packet by ARQ packet. Therefore, the crypto overhead is only applied once, not on every transmission, as in 2G. This represents a large increase in 3G throughput that is often overlooked when comparing system performance with 2G systems.

**FIGURE 8-8 | Red Side and Black Side ARQ**

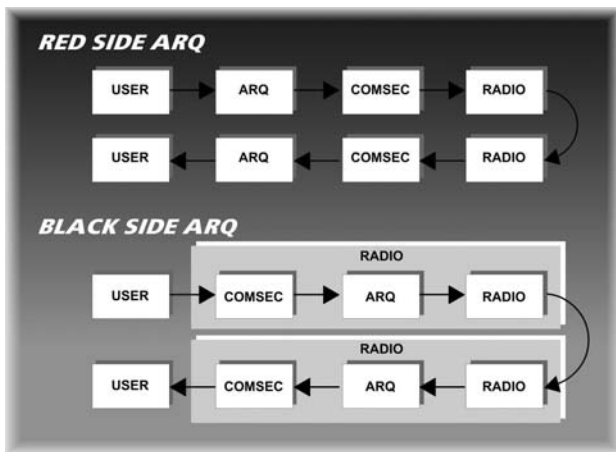

### TRADEOFFS BETWEEN 2G AND 3G

Third Generation HF was developed considerably later than the Second Generation, and contains benefits from over a decade of lessons

learned and also from advanced technology. Third Generation HF was designed primarily for tactical use. There are applications where Second Generation is better suited, particularly where interoperability with legacy equipment is required or when legacy radios and/or modems are to be upgraded. There are several commercial implementations of upgrade kits that will allow existing HF radios to be enhanced to provide automated data services using 2G equipment and technology. However, as a result of the improvements in channel access, throughput, and latency, several applications are now practical and/or substantially improved using 3G technology, including:

**Internet Protocol (IP):** It is relatively simple to send IP-based traffic over HF. The difficulty lies in getting IP systems to work well over HF radios. There are several obstacles to overcome because IP applications are generally:

- + Designed for reliable links.
- + Designed for wired data rates.
- + Expecting low latency.
- + Chatty (including TCP retries).

These problems are overcome by a combination of 3G and radio software features. Networked military software applications use a combination of reliable (TCP-based) and unreliable (UDP-based) protocols. In either case, the applications need nearly error-free data to arrive at the destination to work *effectively*. A 3G IP radio will utilize the xDL protocol suite to insure that the data arrives error-free. This is transparent to the application protocol stack and is much more efficient than relying on TCP for error correction. The HF radio will use a combination of techniques to improve the data rate including utilization of the fastest of the data modes (e.g. HDL+), compression of each transmission, and elimination of all redundant retry packets sent by TCP. The latency problem is addressed by use of STANAG 4538 ALE and packet conglomeration. When a packet is received to be transmitted to another radio, the radio will conglomerate all packets destined to be routed through the destination radio, link with the destination, pass the IP packets, wait for traffic coming from the other direction, and then terminate the link. The speed and trunking nature of this transaction makes it very efficient. Second generation systems can perform similar



IP operations, but are at a disadvantage because of their additional linking time, lower throughput, lack of effective media access control, and resulting network congestion.

**Position Reporting:** Automated Situational Awareness (SA) systems are one of the most powerful military Information Technology systems to be developed in the past decade. These systems automate a process that has been performed manually for millennia. The advantage of the new generation systems is that they can dramatically improve real time knowledge of the location and status of friend and foe.

SA systems rely on timely position reports from the field to work effectively. Most of the commercially available systems have been designed for Line-Of-Sight (LOS) radio systems and/or assume high data rates. The radio systems must be very efficient to avoid consuming the entire HF bandwidth of the net. The use of 3G short messaging satisfies this need by quickly linking and passing the position report without errors.

**Last Ditch Voice:** The latest MELP digital vocoders work very effectively at 600 bps. Real-time digital voice must be sent as a one-way transmission. This means that normal secure voice communications will work down to approximately 5 dB SNR. Although this is considerably more robust than good quality analog voice, it is not as robust as low rate 3G data. By taking advantage of the capabilities of 3G, a feature known as Last Ditch Voice (LDV) is possible. When the operator is linked, the channel degrades, and can no longer pass 600 bps digital voice in real time, LDV can be used. The operator changes the voice mode to LDV, keys the microphone, speaks, and unkeys the microphone. The radio stores the speech in a MELP 600 bps format, and sends it in non-real time to the destination using the 3G data link protocols. At the destination end, the radio automatically plays the speech and stores it for later recall. It may take 60 seconds to send 15 seconds of speech. Although the voice message is not received in real-time, the use of the robust 3G data link protocols allows high quality voice to be delivered in conditions in which voice communication would otherwise be impossible.

## SUMMARY

There are two emerging standards for military and government HF data communications: STANAG 5066 and STANAG 4538.

Both standards send error free data and adapt to the channel condition to push the most data through that the channel will allow.

STANAG 5066 has become the de facto choice for many military organizations because:

- + It provides a cost effective capability by using existing radio and modem technology.
- + Many interoperable implementations can be obtained from various vendors.

STANAG 4538 provides improved performance:

- + Faster linking.
- + Lower latency.
- + Improved network capacity.
- + 2.5 to 5 times better performance particularly at low SNRs.

## CHAPTER 9

### SECURING COMMUNICATIONS

We have reached the age where advancements in radio technology make communicating easy, widespread, and reliable. Now the security of the communication becomes as important as the communication. In this chapter, we'll discuss communications security (COMSEC), that is, methods that keep important communications secure. We'll also talk about transmission security (TRANSEC) — schemes that make it difficult for someone to intercept or interfere with your communications.

There are four things an enemy would like to do with any transmitted information:

1. The enemy wants to know when information is being transmitted. (TRANSEC Concern)
2. The enemy wants to intercept the information. (TRANSEC Concern)
3. The enemy wants to be able to understand and use the information. (COMSEC Concern)
4. If the enemy cannot understand the information, then they would want to stop the transmission of information. (TRANSEC Concern)

There are two key methods to prevent the enemy from succeeding: COMSEC and TRANSEC.

#### COMSEC

COMSEC uses scrambling or cryptographic techniques in order to make information unintelligible to people who do not have a need to know or who should not know. We'll differentiate here between cryptographic or ciphering techniques applied to digital signals and scrambling techniques applied to analog signals.

Cryptography is the process of encrypting (translating) information into an apparently random message at the transmitter and then deciphering the random message by decryption at the receiver.

Historically, sensitive information has been protected codes. The sender would manually encode the messages before transmission and the recipient would manually decode the messages upon receipt. Today's electronic technologies allow the coding/decoding process to occur automatically.

The process involves a mathematical algorithm, coupled with a key, to translate information from the clear to the encrypted state. If sensitive information is transmitted without the protection of cryptography and the information is intercepted, it would require little effort or resources to understand the transmittal. Each individual government has established standards for the degree of protection required for different levels of classified and sensitive information.

In voice communications systems that do not require extremely high security, you can protect against casual eavesdropping by scrambling. Scrambling, as an analog COMSEC technique, involves separating the voice signal into a number of audio sub-bands, shifting each sub-band to a different audio frequency range, and combining the resulting sub-bands into a composite audio output that modulates the transmitter. A random pattern controls the frequency shifting. The technique of scrambling the pattern is similar to sending a message with a decoder ring, like the ones sometimes found in children's cereal boxes. You can, for example, designate that the letter *c* be ciphered as *g*, *a* as *n*, and *t* as *w*, so that when you receive the message *gnw*, you decode it as *cat*.

Descrambling occurs at the receiver by reversing the process. Harris' Analog Voice Security (AVS) allows for easy entry into the communications net because it doesn't require synchronization with other stations.

In digital encryption the data, which may be digitized voice (as described in **Chapter 7**), is reduced to a binary data stream. The cryptographic engine creates an extremely long, non-repeating binary number stream based on a traffic encryption key (TEK). The data stream is added to the cryptographic stream, creating the encrypted data, or cipher text. A binary stream created in this fashion is inherently unpredictable; it also provides a very secure method of protecting information. On the other hand, all analog signals are more predictable and thus less secure.

The data encryption strength, which is the degree of difficulty in determining the message content, is a function of the complexity of the mathematical algorithm coupled with the length of the key. The key is a variable that changes the input to output mapping of the mathematical algorithm. For the type of encryption algorithm just described, the same key variable is required for encryption and decryption operations. This type of algorithm is referred to as a "Symmetric Key Cipher."

Protection of the key is vital. Even if an unwanted organization gains access to the encrypted information and has the algorithm, it is still impossible to decrypt the information without the key. Many governments have developed rigorous key management procedures to protect, distribute, store, and dispose of keys.

In the past, keys were manually loaded into a cryptographic device by using a paper tape, magnetic medium, or plug-in transfer device. Creation and secure delivery of keys to each user were significant problems in both logistics and record keeping.

One type of key management system also used in the commercial sector is public key cryptography. Under this standard, each user generates two keys. One is the public key, "Y," and the other is the private key, "X." The Y value is derived from the X value. The strength of such a system lies in the difficulty of deriving X from Y; what is encrypted with the Y key can only be decrypted with the X key. By openly disseminating the user's public Y key, and retaining sole access to the private X key, anyone can send a secure message to you by encrypting it with your public Y key. You are the only one, though, who can decrypt the message, since only you have the private X key.

In a network using this public key system, two-way secure communications are possible among all network users. This is called an asymmetrical key system. The alternative is a symmetric key system, in which the same key encrypts and decrypts data. Because both the originator and all recipients must have the same keys, this system offers the highest levels of security.

Harris has led the way in developing state-of-the-art electronic means to secure and distribute key material for these symmetric key-based

communications systems. A recent development applicable to radio networks employs Over-The-Air-Rekeying (OTAR). This technique nearly eliminates the need for manual loading of keys and provides secure key management.

OTAR is based upon a benign key distribution system. It includes a key encryption key (KEK) used to encrypt the TEK and any other operational COMSEC or TRANSEC keys. This process is referred to as “wrapping” to differentiate it from traffic encryption. The KEK is the only key that must be initially loaded into both the sending and receiving units. Usually, an initial set of operational keys are loaded at the same time.

After wrapping, subsequent distribution can use any physical or electronic means. In an OTAR system, the wrapped keys are inserted into a message and sent over a radio link to the intended station using error-free transmission protocols (an error would render the keys useless). The link used for transmission is usually secured by the TEK currently in use. Thus, the key material is doubly protected when sent over the air, eliminating any possibility of compromise.

For a higher degree of security, it is common to digitize the voice signal by means of a vocoder, as mentioned in **Chapter 7**. The resulting digital signal is then treated like any data stream.

### TRANSEC

TRANSEC employs a number of techniques to prevent signal detection or jamming of the transmission path. These techniques include hiding the channel or making it a moving target.

Low Probability of Detection (LPD) systems transmit using very low power or spread the signal over a broad bandwidth so that the natural noise in the environment masks the signal.

A related strategy, known as Low Probability of Intercept (LPI), involves transmitting signals in short bursts or over a wide bandwidth to reduce on-the-air time.

The most commonly used TRANSEC technique is frequency hopping. In this system, the transmitter frequency changes so rapidly that it is difficult for anyone not authorized to listen in or to jam the signal. The receiver is synchronized so that it hops from frequency to frequency in a predetermined pattern in unison with the transmitter. Frequency hopping scatters the intelligence over several hundred discrete frequencies. A radio operator listening to one of these frequencies may hear a short "pop" of static. A broadband receiver could perhaps capture all of these little bursts; however, the task of picking these bursts out of the other natural and man-made bits of noise would be daunting, requiring a team of experts several hours just to reassemble a short conversation. Jamming one channel would have minimal impact on the hopping communicator. To effectively jam a frequency-hopping radio, most or all of the frequencies that the hopping communicator uses would have to be jammed, thus preventing the use of those frequencies by the adversary as well.

## SUMMARY

COMSEC uses cryptography or scrambling to make information unintelligible to people who do not have a need to know.

- + The security level of a COMSEC system depends on the mathematical soundness of the algorithms and the number of variables in the key.
- + Protecting the key is vital to securing the transmitted information.
- + Public key cryptography is widely used in the commercial sector.

Over-The-Air-Rekeying (OTAR) eliminates the need for manual loading of keys and provides a more secure method of key management.

TRANSEC protects the transmitted signal itself, to prevent signal detection or jamming of the transmission path.

- + Low Probability of Detection (LPD) systems use spread-spectrum and other techniques to “hide” the signal beneath the natural noise level.
- + Low Probability of Interception (LPI) radios transmit compressed digital data in short bursts or over a wide bandwidth.
- + Frequency-hopping radio systems jump rapidly in unison, from one frequency to another in apparently random patterns, using a common timing reference.



## CHAPTER 10

### FUTURE DIRECTIONS

In the earlier chapters, we presented the principles of HF communications and gave you some insight into where the technology of HF communications has been and where it is now.

Today, and for the future, HF radio fills two roles. First, it is the primary medium for long-haul communications, where there is a need for a mobile or quickly deployable system to support emergency or military operations. Second, it is a highly cost-effective alternative and backup to other communications media, such as telephone and satellite systems. In either capacity, HF has to support a variety of traffic, including voice, data, and images.

Advances in digital signal processing (DSP) technology will lead to continued improvements in HF systems and equipment. In particular, we expect to see advances in the following areas:

#### ALE PERFORMANCE

Higher-speed devices allow more precise and frequent link quality analysis, enabling better and faster frequency selection. Also, higher ALE system data rates of the ALE system allow faster transmission of channel-quality information, as well as improved channel estimation and evaluation techniques.

#### MODEM DESIGN

Adaptive channel equalization improvements have allowed increases in channel bit rates to 9600 bps in a 3-kHz channel, giving HF communication an economical advantage over other long-haul communications media. For certain less restricted applications allowing greater than 3-kHz bandwidth, transmission of 64 kbps can be achieved over HF. Advances in DSP devices improve adaptive filtering, which combats unintentional interference and jamming. Modem capabilities will expand so that waveforms will be optimized for use, not only with HF, but for other frequencies in future multiband radios.

## NETWORKING

Improvements in HF system performance and computer-based technology provide networks that achieve highly reliable levels of communications through automatic message routing and adaptive signaling techniques. Network design includes ways to periodically determine the link quality between each pair of its stations at each of their assigned frequencies, and send this information to all nodes so that they route messages automatically. Thus, if station A transmits a message to B, a routing algorithm determines if direct point-to-point communication is possible or whether the message from A to B must be routed through other stations.

The ability to transfer information over a network enables simultaneous transfer of several messages or speeds up the transfer of long messages. For example, multiple radios in a station simultaneously send messages to several destinations over several channels. Also, a long message can be divided so that portions of it can be sent in parallel. If channel bandwidths increase beyond the current 3 kHz restriction (which requires international agreement), improvements in real-time channel equalization techniques will allow data transmission rates considerably higher than the current rate of 9600 bps.

HF radio is becoming an increasingly important element in multi-media networks that incorporate landline, VHF, and UHF. Recent and projected improvements in HF communications technology mean that constraints on the passing of information through networks that include an HF leg will be significantly reduced.

## RADIO DESIGN

Radios will continue to move toward multiband designs, ranging from MF through UHF in a single radio. Digital circuits will continue to replace analog circuits, resulting in lower costs and more versatile and reliable designs. Digital processing circuitry will handle higher and higher frequencies, as higher speed analog-to-digital converters and other DSP circuits become available.

The versatility made possible by “going digital” allows radios to be quickly reprogrammed for broadband modes of operation, resulting in new levels of performance such as higher data rates and improved frequency-hopping capabilities.

## APPENDIX A

### STANDARDS

HF communications standards created by the US Government, NATO, and other organizations greatly influence the design of HF equipment and systems. These standards apply to equipment specifications, waveform design, communications protocols, and computer control. They serve to:

- + Define minimum performance requirements.
- + Ensure interoperability among systems used by different organizations.
- + Reduce ambiguous descriptions of equipment and systems by providing a common language in equipment specifications and in defining the operating environment.

A summary of some of the most important HF radio communication standards includes:

- + Federal Standard 1045A — Second Generation HF Radio Automatic Link Establishment. Specifies automated radio features including frequency scanning, selective calling, ALE, LQA, and sounding, which ensure interoperability of radio systems. It is a subset of, and is compatible with, MIL-STD-188-141B Appendix A ALE.
- + MIL-STD-188-141B — Interoperability and Performance Standards for Medium and High-Frequency Radio Equipment. Establishes requirements for interoperability and performance for HF radio equipment. The main body of standard covers HF radio specifications. The optional appendices contain details about implementing ALE systems, waveforms, signal structures, protocols, and LQA. It also includes Linking Protection.
- + MIL-STD-188-110B — Interoperability and Performance Standards for Data Modems. Establishes requirements that ensure specified

levels of performance of voice-frequency data modems used in communications systems. This standard includes the 75-2400 bps Serial Tone, 3600-9600 bps QAM, FSK, and 39 tone waveforms. It is compatible with the equivalent waveforms in STANAG 4539.

- + STANAG 4285 — Characteristics of 75-3600 bps Single-Tone Modulators/Demodulators for HF Links. Defines the parameters that insure interoperability between single-tone modems designed for communicating via HF radio links. This standard is often used for NATO HF Maritime Broadcast. This standard is largely obsolete because of STANAG 4539.
- + STANAG 4529 — Modification of NATO STANAG 4285 to deliver data and voice in 1240 Hz bandwidth at rates up to 1200 bps.
- + STANAG 5066 — is a NATO standard data communications protocol that defines 2nd generation system-system communications over variable speed data links. It provides a general, open, and interoperable system for data communications over HF radio. It also defines protocols to efficiently exchange e-mail over HF circuits.
- + STANAG 4538 — Technical Standards for an Automatic Radio Control System for HF Communication Links. It is a 3rd generation HF automation standard. This standard defines a 3rd generation ALE system that has two different modes: Fast Link Setup (FLSU) and Robust Link Setup (RLSU). It also has a highly efficient ARQ data link protocol which is combined with robust waveforms.

## APPENDIX B

### GLOSSARY

**ADAPTIVE EXCISION FILTER** — A signal-processing technique that improves data transmissions. It seeks and suppresses narrowband interference in the demodulator input and reduces the effects of co-channel interference (interference on the same channel that is being used).

**ADAPTIVE SYSTEM** — A system that automatically adjusts its parameters to improve its performance in response to changing conditions. ALE systems are often referred to as “Adaptive Systems.”

**AGC** (Automatic Gain Control) — Circuit employed to vary gain or amplifier in proportion to input signal strength so that output remains at a constant level.

**ALE** (Automatic Link Establishment) — A technique that permits radio stations to make contact with one another automatically.

**AM** (Amplitude Modulation) — A technique to transmit information in which the amplitude of the radio frequency carrier is modulated by the audio input and the full carrier and both sidebands are transmitted.

**AME** (Amplitude Modulation Equivalent) — A method of single sideband transmission where the carrier is reinserted to permit reception by conventional AM receivers.

**AMPLITUDE** — The peak-to-peak magnitude of a radio wave.

**ANTENNA COUPLER/TUNER** — A device between the transmitter and antenna that modifies the characteristics of the load presented to the transmitter so that it transfers maximum power to the antenna.

**ANTENNA DIRECTIVE GAIN** — The ratio of radiation intensity in a certain direction to the average radiation intensity.

**ANTENNA POWER GAIN** — The ratio of radiated power in a given direction to the antenna input power.

**ARQ** (Automatic Repeat Request) — Data transmission technique for error-free data transfer.

**ASCII** (American Standard Code for Information Interchange) — The standard code for digital data interchange. ASCII uses a coded character set consisting of a 7-bit coded character (8 bits including parity check).

**ASYMMETRICAL KEY SYSTEM** — A key management system that allows two-way secure communications among all users that have a public key and a private key.

**ASYNCHRONOUS** — A data communication system that adds start-and-stop signal elements to the data for the purpose of synchronizing individual data characters or blocks.

**ATMOSPHERIC NOISE** — Radio noise caused by natural atmospheric processes (primarily by lightning discharges in thunderstorms).

**BANDPASS FILTER** — A filter that passes a limited band of frequencies. It is used to remove noise and spurious signals generated in the exciter or output frequency harmonics from the power amplifier.

**BANDWIDTH** — The range of frequencies occupied by a given signal.

**BASEBAND** — The frequency band occupied by a signal prior to radio frequency carrier modulation or following demodulation.

**BAUD** — A unit of signaling speed equal to the number of symbols, i.e., discrete signal conditions per second.

**BER** (Bit Error Ratio) — The number of erroneous bits divided by the total number of bits communicated.

**BINARY** — Number system having base of 2, using only the symbols 0 and 1.

**BIT** — One binary digit (0 or 1).

**BLOS** (Beyond Line-of-Sight) — Communications that occur over a great distance.

**BROADBAND** — A term indicating the relative spectrum occupancy of a signal as distinguished from a narrowband signal. A broadband signal typically has a bandwidth in excess of twice the highest modulating frequency. Synonym: Wideband.

**CARRIER** — A radio frequency signal that may be modulated with information signals.

**CCIR** (International Radio Consultative Committee) — An organization of the International Telecommunications Union (ITU) that studies technical questions related to radio communications.

**CHANNEL** — A unidirectional or bidirectional path for transmitting and/or receiving radio signals. Also is used to describe a preset for a particular frequency.

**CHANNEL EQUALIZER** — A signal processing technique that improves data transmissions by compensating for variations in the channel characteristics as data is received.

**CIPHER TEXT** — Encrypted data.

**COLLOCATION** — The act or result of placing or arranging side by side.

**COMSEC** (Communications Security) — Scrambling or cryptographic techniques that make information unintelligible to unauthorized persons.

**COSMIC NOISE** — Random noise originating outside the earth's atmosphere.

**CRYPTOGRAPHY** — A COMSEC technique that translates (encrypts) information into an apparently random message and then interprets (deciphers) the random message by decryption.

**CW** (Continuous Wave) — A radio wave of constant amplitude and constant frequency. Also, Morse code.

**D LAYER** — First layer in the ionosphere. Reaches maximum ionization when the sun is at zenith and dissipates quickly toward sunset.

**dB** ( Decibel) — The standard unit for expressing transmission gain or loss and relative power ratios.

**DE-INTERLEAVING** — Process used by a demodulator to reverse interleaving and thus correct data transmission errors used in FEC coding.

**DEMODULATION** — The process in which the original modulating signal is recovered from a modulated carrier.

**DIPOLE ANTENNA** — A versatile antenna that is usually a wire fed at the center of its length. Its orientation provides either horizontal or vertical polarization.

**DIRECT WAVES** — Travel in straight line, becoming weaker as distance increases.

**DIRECTIONAL ANTENNA** — An antenna that has greater gain in one or more directions.

**DSP** (Digital Signal Processing) — A recently developed technology that allows software to control digital electronic circuitry.

**DTMF** (Dual-Tone-Multi-Frequency) — Refers to DTMF signaling, which is typically used in telephone systems.

**E LAYER** — The mid-level of the ionosphere which reaches maximum ionization at noon. It begins dissipating toward sunset and reaches minimum activity at midnight. Irregular cloud-like formations of ionized gases occasionally occur in the E layer.

**EMI** (Electromagnetic Interference) — An electromagnetic disturbance that degrades communications performance. Synonym: Radio Frequency Interference (RFI).



**ENCRYPTION** — Process of translating information into an apparently random message.

**ERP** (Effective Radiated Power) — Equivalent power transmitted to the atmosphere, which is the product of the transmitter power output multiplied by the gain of the antenna.

**ERROR DETECTION** — An error correction technique that uses binary code words to modify data messages by systematically adding check bits to detect errors in received words.

**EXCITER** — The part of the transmitter that generates the modulated signal for a radio transmitter.

**F LAYER** — The uppermost and most heavily ionized region of the ionosphere. Important for long-haul communications, since this layer remains ionized even after sunset.

**FADING** — The variation of the amplitude and/or phase of a received signal due to changes in the propagation path with time.

**FEC** (Forward Error Correction) — A system of error control for data transmission whereby the receiver can correct any code block that contains fewer than a fixed number of bits in error.

**FLSU** (Fast Link Setup Protocol) — A 3rd generation ALE protocol used in STANAG 4538 systems.

**FM** (Frequency Modulation) — A form of modulation where the frequency of a carrier varies in proportion to an audio modulating signal.

**FOT** (Frequency of Optimum Transmission) — The highest frequency predicted to be available for sky wave transmission for a given path and time for 85 percent of the maximum usable frequency (MUF).

**FREQUENCY** — The number of completed cycles per second of a signal, measured in Hertz (Hz).

**FREQUENCY HOPPING** — The rapid switching (hopping) of radio system frequency for both the receiver and transceiver from frequency to frequency in apparently random patterns, using a common timing reference.

**FSK** (Frequency Shift Keying) — A form of modulation in which a digital signal shifts the output frequency between specific in-band frequencies.

**GAIN** — The ratio of the value of an output parameter, such as power, to its input level. Usually expressed in decibels.

**GROUND REFLECTED WAVE** — The portion of the propagated wave that is reflected from the surface of the earth between the transmitter and receiver.

**GROUND WAVE** — A radio wave that is propagated over the earth and ordinarily is affected by the presence of the ground.

**HF** (High Frequency) — Nominally, the band from 3 to 30 MHz; in practice, the lower end of the HF band extends to 1.6 MHz.

**Hz** (Hertz) — Basic unit for frequency.

**IF** (Intermediate Frequency) — A frequency used within equipment as an intermediate step in transmitting or receiving.

**IMPEDANCE** — Opposition to current flow of a complex combination of resistance and reactance.

**INCIDENT ANGLE** — The angle at which sky waves enter the ionosphere.

**INTERLEAVING** — A technique that increases the effectiveness of FEC codes by randomizing the distribution of errors in communication channels characterized by error bursts.

**IONCAP** (Ionospheric Communications Analysis and Prediction) — A popular and effective propagation prediction program that predicts sys-

tem performance at given times of day as a function of frequency for a given HF path and a specified complement of equipment.

**IONOSPHERE** — A region of electrically charged particles or gases in the earth's atmosphere extending from 50 to 600 kilometers (approximately 30 to 375 miles) above the earth's surface.

**ISB** (Independent Sideband) — Double sideband transmission in which the information carried by each sideband is different. An ISB circuit uses 6 kHz of bandwidth

**JAMMING** — Deliberate interference that results from transmission on operating frequencies with the intent to disrupt communications.

**KEK** (Key Encryption Key) — Used in digital encryption.

**KEY** — A variable that changes the mathematical algorithm in cryptography.

**KEY GENERATOR** — A device or process that generates the variable for a cryptographic encoding system.

**LOS** (Line of Sight) — A term that refers to radio signal propagation in a straight line from the transmitter to a receiver without refraction; generally extends to the visible horizon.

**LPD** (Low Probability of Detection) — Techniques for minimizing the probability that the transmitted signal is detected by an unauthorized party.

**LPI** (Low Probability of Intercept) — Techniques for minimizing the likelihood of the intelligence on a transmitted signal being recovered by an unauthorized party.

**LQA** (Link Quality Analysis) — A technique for real-time channel evaluation in which radios measure and store values indicating the relative quality of a radio link at different assigned frequencies.

**LUF** (Lowest Usable Frequency) — The lowest frequency in the HF band at which the received field intensity is sufficient to provide the required signal-to-noise ratio.

**MAIN LOBE** — In an antenna radiation pattern, the lobe containing the direction of maximum radiation intensity.

**MFSK** (Multi-tone Frequency Shift Keying).

**MODEM** (MODulator-DEmodulator) — A device that modulates and demodulates signals. The modem converts digital signals into analog form for transmitting and converts the received analog signals into digital form.

**MODULATION** — The process, or result of the process, of varying a characteristic of a carrier in accordance with a signal from an information source.

**MUF** (Maximum Usable Frequency) — The upper limit for the frequencies used at a specified time for radio transmission between two points via ionospheric propagation.

**MULTIPATH** — The propagation phenomenon that results in radio signals reaching the receiving antenna by two or more paths.

**MULTIPATH SPREAD** — The range of timed differences that it takes for radio signals to reach the receiving antenna when they arrive from several routes, which may include one or more sky wave paths and/or a ground-wave path. The effect of multipath spread is minimized by selecting a frequency as close as possible to the MUF.

**NVIS** (Near-Vertical Incidence Sky wave) — A technique for transmitting over relatively short ranges by ionospheric refraction using very high incident angles.

**OHM** — Unit of measurement of resistance. Its symbol is  $\Omega$ .

**OMNIDIRECTIONAL ANTENNA** — An antenna whose pattern is non-directional in azimuth.

**OTAR** (Over-The-Air-Rekeying) — A method for sending new keys to crypto from one radio to another. This technique eliminates the need for manual loading of encryption keys and provides a more secure method of key management.

**PARALLEL TONE MODEM** — Carries information on simultaneous audio tones, where each tone is modulated at a low-keying rate.

**POLARIZATION** — The orientation of a wave relative to a reference plane. Usually expressed as horizontal or vertical in radio wave terminology.

**POWER AMPLIFIER** — The part of the transmitter that boosts the output power of the radio signal to the desired wattage before sending it to the transmitting antenna.

**PREAMBLE** — A known sequence of bits sent at the start of a message which the receiver uses to synchronize to its internal clock.

**PROPAGATION** — The movement of radio frequency energy through the atmosphere.

**PUBLIC KEY CRYPTOGRAPHY** — A type of key management system used in the commercial sector. Under this standard, each user generates two keys, a public key and a private key. The strength of such a system lies in the difficulty of deriving the private key from the public key.

**RADIATION PATTERN** — Pattern determined by an antenna's design and strongly influenced by its location with respect to the ground. Radiation patterns are frequency dependent.

**RAU** (Remote Access Unit).

**REFRACTION** — The bending of a radio wave as it passes obliquely from one medium to another.

**RLSU** (Robust Link Setup Protocol).

**RMS** (Root Mean Square).

**RTCE** (Real-Time Channel Evaluation) — Techniques used to select frequencies, adjust data rates, or change modulation schemes in adaptive radio systems.

**SATCOM** (Satellite Communications).

**SCRAMBLING** — A COMSEC technique that involves separating the voice signal into a number of bands, shifting each band to a different audio frequency range, and combining the resulting bands into a composite audio output that modulates the transmitter.

**SERIAL TONE MODEM** — Carries digital information on a single audio tone.

**SHORT WAVE** — Radio frequencies above 3 MHz.

**SID** (Sudden Ionospheric Disturbance) — Abnormally high ionization densities caused by solar flares, resulting in a sudden increase in radio wave absorption and loss or degradation of HF communications.

**SIDEBAND** — The spectral energy, distributed above or below a carrier, resulting from a modulation process.

**SKY WAVE** — A radio wave that is reflected by the ionosphere.

**SNR** (Signal-to-Noise Ratio) — The ratio of the power in the desired signal to that of noise in a specified bandwidth.

**SOFT-DECISION DECODING** — An error-correction technique where a group of detected symbols that retain their analog character are compared against the set of possible transmitted code words. A weighing factor is applied to each symbol in the code word before a decision is made about which code word was transmitted.

**SPORADIC E** — Layer found in the E Layer of the ionosphere. Supports propagation of sky waves at the upper end of the HF band and beyond.

**SPREAD SPECTRUM** — A technique used to overcome deliberate radio communications interference, in which the modulated information is transmitted in a bandwidth considerably greater than the frequency content of the original information.

**SSB** (Single Sideband) — A modulation technique in which the carrier and one sideband (upper or lower) are suppressed so that all power is concentrated in the other sideband.

**STORE AND FORWARD** — A technique where information is stored until a communication link is established and then sent.

**SUNSPOT CYCLE** — Eleven-year cycle of sunspots which generate bursts of radiation that increase levels of ionization.

**SURFACE WAVES** — Travel along the surface of the earth and may reach beyond the horizon.

**SYMMETRIC KEY SYSTEM** — A key management system in which the same key encrypts and decrypts data.

**SYNCHRONOUS** — A form of data communications that uses a preamble to alert the data receiver that a message is coming and to allow it to synchronize to an internal bit clock.

**TAKE-OFF ANGLE** — The angle between the axis of the main lobe of an antenna pattern and the horizontal plane at the transmitting antenna.

**TCP** (Transmission Control Protocol) — One of the core protocols of the Internet protocol suite. Using TCP, programs on networked computers can create connections to one another, over which they can send data.

**TEK** (Traffic Encryption Key) — Used in digital encryption.

**TIU** (Telephone Interface Unit).

**TRAFFIC** — The information moved over a communications channel.

**TRANSCEIVER** — Equipment using common circuits in order to provide transmitting and receiving capability.

**TRANSEC** (Transmission Security) — Techniques that prevent signal detection or jamming of the transmission path.

**VERTICAL WHIP ANTENNA** — An omnidirectional antenna that has low take-off angles and vertical polarity.

**VOCODER** — A device that converts sounds into a data stream that can be sent over an HF channel. Short for voice coder-decoder.

**WAVELENGTH** — Distance between point on loop of wave to corresponding point on adjacent wave.



## FURTHER READING

We hope this book is helpful in introducing you to the concepts and benefits of HF radio technology. For more information, here's some recommended reading:

Johnson, Eric, et al. (1997). Advanced High Frequency Radio Communications Artech House.

NTIA/ITS. (1998). High Frequency Radio ALE Application Handbook. [www.its.bldrdoc.gov/pub/oa-rpt/hf-ale/handbook/](http://www.its.bldrdoc.gov/pub/oa-rpt/hf-ale/handbook/).

Mayor, Jonathan L. (1992). The Radio Amateur's Digital Communications Handbook. Blue Ridge Summit, Pa.: TAB Books.

Laster, Clay. (1994). The Beginner's Handbook of Amateur Radio. Blue Ridge Summit, Pa.: TAB Books.

Sabin, W. E. (1995). Single Sideband Systems and Circuits. New York, NY: McGraw-Hill.

U.S. Marine Corps Antenna Handbook. (2001). [www.doctrine.quantico.usmc.mil](http://www.doctrine.quantico.usmc.mil).

Schetgen, Robert (Ed.) (2005). The ARRL Handbook for Radio Communication. Newington, Conn.: Amateur Radio Relay League.

Straw, Dean. (2003). The ARRL Antenna Book. Newington, Conn.: Amateur Radio Relay League.

Department of Army. FM 24-18, Tactical Single-Channel Radio Communication Techniques. [pubs.armystudyguide.com](http://pubs.armystudyguide.com).

We appreciate your input. Did you enjoy this introduction? Did you find it interesting and informative? Our goal is to educate and inform you. Let us know if we were successful!

To contact us:

Online: <http://www.harris.com>

Phone: (585) 244-5830  
Director, Marketing Communications

Mail: Harris Corporation  
RF Communications Division  
1680 University Avenue  
Rochester, New York 14610  
USA